

Automatic Door Equipment

Supplied, Supported, Independent

We supply automatic equipment and support to independent companies working in the field of door automation.

Our forté is supplying our heavy duty operating equipment at realistic prices.

Our equipment is simple to fit, heavy duty and affordable. High specification and very adaptable, our equipment is fast becoming the industry leader within automation

SLIDING OPERATORS // SWING OPERATORS
FOLDING DOORS // RETROFIT KITS

Key Benefits / Features

- + Full technical support
- + FREE TRAINING COURSES
- + Low cost maintenance
- + Architectural wording and specifications available
- + CAD drawings
- + Next day delivery
- + Comprehensive guarantee
- + Economical and reliable
- + Fully compliant with BS7036:1996
- + Intelligent control units with simple setup
- + Designed by engineers with over 30 years experience in automatic pedestrian doors

Call: 0845 643 0013

GLOBAL
AUTOMATICS LTD



The first independent, customer-branded sliding door operator

Premier-Slide 100

www.global-automatics.com

+ The only independent sliding door operator on the market. – completely unbranded

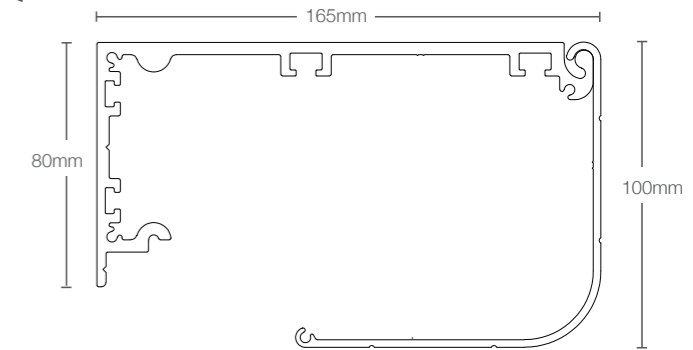

Flush-mounted switch



Canopy-mounted switch



Surface-mounted switch

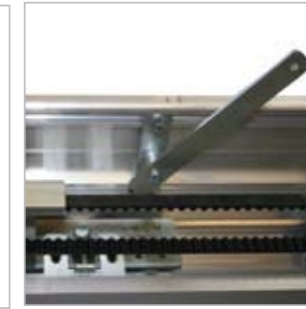

Dedicated canopy stay



Dedicated sensor connections

Key Features

- + Only 10cm high – one of the most versatile operators on the market
- + Highly reliable – 18 months warranty*
- + Designed for easy installations, repairs and servicing
- + Highly precise microprocessor-driven control unit with optimum adjustments
- + Original heavy duty 100w Dunker motor gearbox
- + Interlock function for secured access doors
- + Self setup system and monitored battery backup – in accordance with BS7036:1996
- + Canopy stay – to hold up the canopy for easy installation and maintenance
- + Designed and manufactured in the UK

Safety Functions

- + Monitored sensors for the safest possible automatic door
- + Intelligent emergency escape system – will open, close or continue in normal operation upon power failure
- + Emergency stop function
- + Dedicated removable plugs for connecting all types of automatic door sensors

Motor Gearbox

- + Heavy duty 100w Dunker motor with built-in electric brake



Heavy Duty Motor Gearbox

Control Unit

- + An intelligent control unit with variable adjustments on all functions to allow easy integration
- + Dedicated connections for each sensor
- + 'Plug and play' sensors available

Customer Operating Modes

- + Automatic
- + Exit Only or Enter Only
- + Hold Open
- + Partial Opening (same functions as automatic but with an adjustable reduced opening)
- + Auto-width (Self-adjusting opening, dependant on the frequency of pedestrian traffic)
- + Pharmacy
- + Closed

Access Panel

- + Acts as a switch for customers to change the door's function
- + 'Engineers' mode allows for easy adjustments and set-up
- + Faults diagnostics with issues displayed on screen
- + Uploaded with your logo and telephone number
- + Screen saver and auto lock functions to prevent unauthorised usage

Drive System and Track

Heavy duty steel brackets, reinforced toothed belt and a high quality extruded housing make this operator suitable for heavy and high usage door sets. Our use of nylon wheels on an aluminium track make for the quietest possible operation. Canopies are available in SAA or Mill for powder coating

* The motor gearbox and control unit have an 18 month warranty. All other components, including batteries and mechanical items, have a 12 month warranty.