

# MIRAGE



## MANUFACTURER'S STATEMENT

5911750 2004.5

Read this Operation Manual carefully before use, to ensure proper operation of this Optex sensor. Failure to read this Operation Manual may cause improper sensor operation and may result in serious injury or death. This product is a non-contact activating switch intended for mounting in the header or the ceiling of an automatic door. Do not use it for any other applications; otherwise proper operation and safety cannot be guaranteed.

**Cautions:**

1. Follow the instructions (especially **Note**) in this Operation Manual when installing and adjusting the sensor.
2. When setting the sensor's area pattern, make sure there is no traffic around the installation site.
3. Before turning the power on, check the wiring to prevent damage or malfunction of equipment that is connected to the sensor.
4. Do not wash, disassemble, rebuild or repair the sensor by yourself; otherwise it may cause electric shock or breakdown of the sensor.
5. Only use the sensor as specified in the supplied instructions.
6. Be sure to install the sensor in accordance with the local laws and standards of your country.
7. Before leaving the jobsite, be sure that this sensor is operating properly and instruct the building owner/operator on proper operation of the door and this sensor.

## SPECIFICATIONS

Model	: MIRAGE	Output	: "Form C" relay 50V 0.3A Max. (Resistance Load)
Cover color type	: Black	Relay Hold Time	: 0.5 sec.
Mounting Height	: 3.0m (9'10") Max.	Response Time	: < 0.3 sec.
Detection Area	: See "Detection Area"	Operating Temperature	: -20°C to +55°C (-4°F to +131°F)
Detection Method	: Active Infrared Reflection Method	Weight	: 260g (9.2oz)
Detection Angle	: ±4° adjustable by 1° every one click	Accessories	: 1 Cable 3m (9'10") 1 Operation Manual 1 Area Adjustment Tool
Adjustments	(Deep / Shallow)		
Detection Width	: 4 type selectable with Adjustment Shutters		
Adjustments	(Not angle adjustment)		
Power Supply	: 12 to 30V AC / DC		
Current Draw	: 200mA Max. (At 12V AC)		
Operation Indicator	: Green / Stand-by Red / 1st Row Detection Active Orange / Other Row Detection Active		

\* The specifications herein are subject to change without prior notice due to improvements.

## OUTER DIMENSIONS

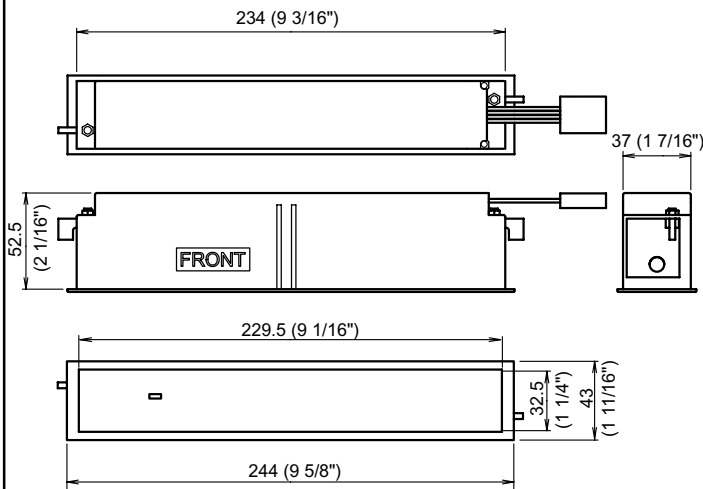

Mounting Board Thickness : < 26mm (1")

mm (inch)

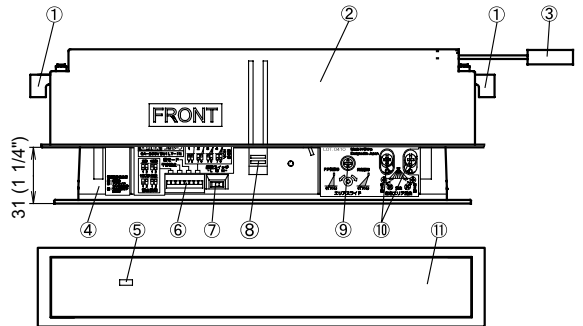

- |                         |                                |
|-------------------------|--------------------------------|
| 1 : Mount lever(s)      | 7 : Sensitivity Switch         |
| 2 : Bracket             | 8 : Stopper                    |
| 3 : Connector           | 9 : Area Adjustment Screw      |
| 4 : Main body           | 10 : Width Adjustment Shutters |
| 5 : Operation Indicator | 11 : Detection Window          |
| 6 : Dipswitches         |                                |

# INSTALLATION

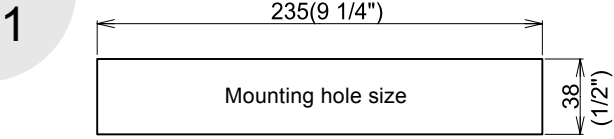

Drill the Mounting hole either under the header or Ceiling.

**Note**

Be sure that the mounting position is within the value of those in "SPECIFICATION".

**2** The cable is arranged to connect to the door controller properly as shown below.

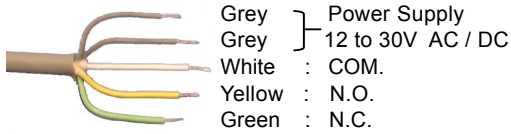

**Note**

Connect the cable when main power is turned off.

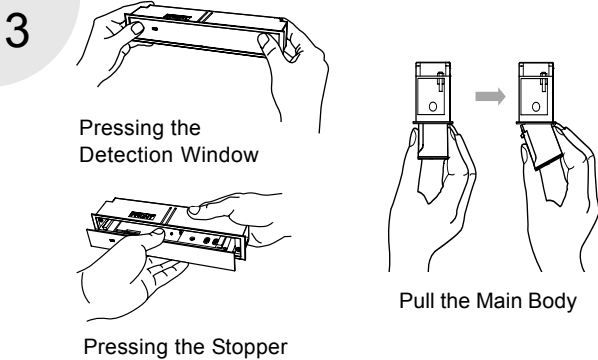

By pressing the Detection Window as shown, the Main Body appears. Then remove the Main Body from the Bracket by pressing the Stopper( OUTER DIMENSIONS 8 ).

**4** **Note**

The cable between the Main Body and the Bracket cannot be removed.

Do not pull the cable strongly, otherwise it may be damaged.

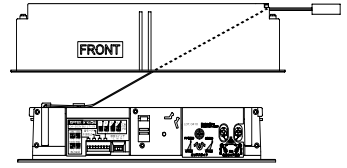

**5**

Plug the Connector for the sensor to that for the cable.

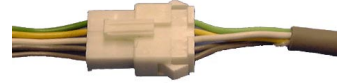

**6**

Fold the Mounting Levers inside. Insert it to the Mounting hole so that the "FRONT" on the Bracket comes in front.

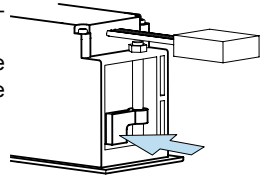

**7**

Fix the Bracket in the mounting hole with the screws on both sides.

**Note**

Be sure to fix firmly, otherwise the sensor may fall off resulting in injuries.

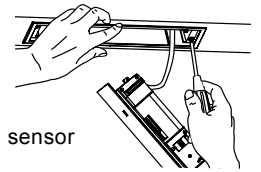

**8**

Place the Main Body on the Bracket referring to the "ADJUSTMENT". Supply power to the sensor. Adjust the detection area and set the various Switches.

**Note**

Make sure that you connect the cable correctly to the Control Unit of the door before turning the power on.

# DETECTION AREA

Detection Areas are shown in the figure below.

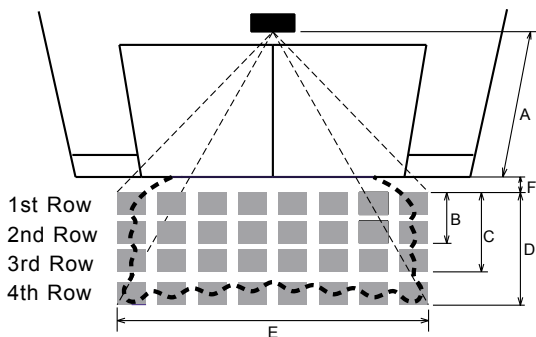

Provided Detection Row type	1st	2nd	3rd	4th
Presence Detection	○	○	×	×
Motion Detection	○	○	○	○

After adjustment, turn the power off and on again, be sure to walk-test all of detection areas.

\* The values of the chart below is of the Emitting Spots, but not of the Detection Area.

The actual Detection Area may become smaller depending on the ambient light and the colour / material of object and the floor as well as the entry speed of object.

	[ m ]				
A	2.00	2.20	2.50	2.70	3.00
B	0.42	0.47	0.53	0.57	0.64
C	0.85	0.94	1.07	1.15	1.28
D	1.50	1.65	1.88	2.03	2.25
E	2.07	2.28	2.59	2.80	3.11
F	0.21	0.23	0.26	0.28	0.31

	[ feet , inch ]				
A	6' 6 3/4"	7' 2 5/8"	8' 2 7/16"	8' 10 5/16"	9' 10 1/8"
B	1' 4 11/16"	1' 6 3/8"	1' 8 7/8"	1' 10 1/2"	2' 1"
C	2' 9 5/8"	3' 15/16"	3' 6"	3' 9 3/8"	4' 2 3/8"
D	4' 11 1/8"	5' 5 1/16"	6' 1 7/8"	6' 7 13/16"	7' 4 11/16"
E	6' 9 5/8"	7' 5 3/4"	8' 6"	9' 2 3/16"	10' 2 3/8"
F	8 1/8"	8 15/16"	10 3/16"	11"	1' 3/16"

# ADJUSTMENT

## 1 Fixing and removing the Main Body

Place the Main Body in the Bracket, Paying attention to direction of the sensor.

Main body can be fixed in the Bracket when pushing the Detection Window fully.

Main Body (Setting part) appears when pushing the Detection Window again.

After adjustment, Check the operation when the Main Body is placed in the Bracket.

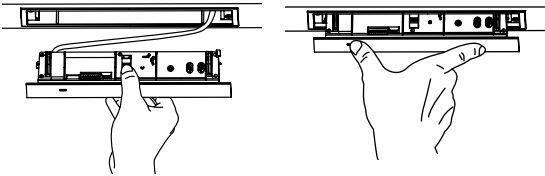

## 2 Adjusting the Pattern Width

Setting the Width adjustment shutters

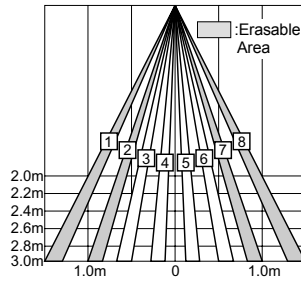
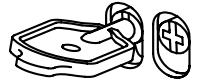

- Opens All Areas
- 1|2 Eliminate
- 7|8 Eliminate
- 1|2|7|8 Eliminate

**Note** Setting the pattern for exact door opening may give a slow response to side approaching traffic.

## 3 Adjusting the Pattern Depth

Setting the Row with the Dipswitch7 & 8.

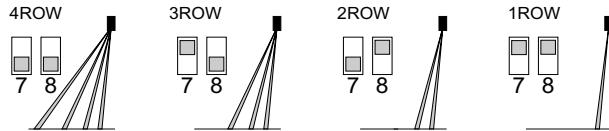

Adjusting the Depth Angle between  $-4^{\circ}$  to  $4^{\circ}$  ( $1^{\circ}$  per click).

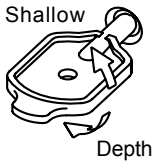

Pattern when Standard

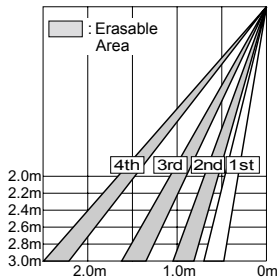

Pattern when changed  $-4^{\circ}$  to Shallow (inside).

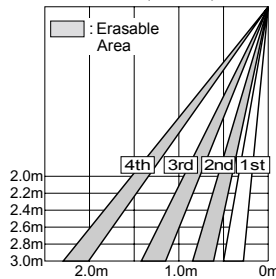

Pattern when changed  $4^{\circ}$  to Deep (outside).

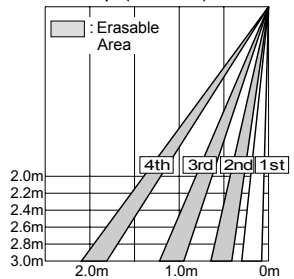

**Note** Set the pattern for actual traffic. It may cause slow activation for the traffic from the front, when the Row is eliminated.

## 4 Setting of Sensitivity Switch and Dipswitches

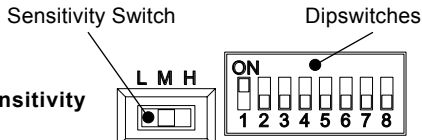

### Setting the Sensitivity

Normally set to "M".  
"H" increases the sensitivity and "L" lowers the sensitivity.

### Setting the Presence timer

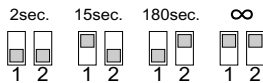

1st Row and 2nd Row from door provide the presence detection.

- (1) Select the presence detection time.
- (2) Turn the power off and on again. Otherwise it may leave door open for the duration of the presence time set.
- (3) After making sure that the door closes, wait for 10 seconds before entering the detection area to set the Presence timer.

### Setting the Frequency Function ( interference Prevention )

Four different frequencies can be set by adjusting the Dipswitch 3 and 4.

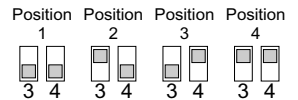

**Note** When two or more sensors are installed close to each other, it is possible that they interfere. When that happens, change the Frequency.

### Setting the Snow mode

Set the Dipswitch 5 and 6 to snow mode, if the sensor is used in a region with snow or a lot of insects.

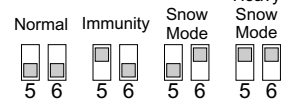

## CHECKING

Check the operation according to the chart below.

Entry motion (image)						
Sensor status	Power OFF	Stand-by	Motion Detection Active	Motion or Presence Detection Active		Stand-by
Operation indicator	OFF	Green	Orange		Red	Green
Output						

**Note** The door may open once after the power is switched on.

## Inform the following items to the building owner/operator

1. When turning the power on, always walk-test the sensor pattern to ensure proper operation.
2. Always keep the detection window clean. If dirty, wipe the window with a damp cloth (Do not use any cleaner or solvent).
3. Do not wash the sensor with water.
4. Do not disassemble, rebuild or repair the sensor yourself; otherwise electric shock may occur.
5. Contact your installer or the sales engineer if you want to change the settings.
6. Do not place an object that moves or emits light in the detection area. (Ex. Plant, illumination etc.)
7. Do not paint the Detection Window.

## TROUBLESHOOTING

Trouble	Possible Cause	Solution
Does not operate	Power supply is not adequate.	Adjust to stated voltage.
	Connection Failure.	Check the wiring and the connector.
Does not operate consistently	Dirty detection window.	Wipe the detection window with a damp cloth (Do not use any cleaner or solvent).
	Sensitivity is Low.	Set the Sensitivity Switch "H".
Operates by itself (Ghosting)	There is an object that moves or emits light in the detection area. (Ex. plant, illumination etc...)	Remove the object.
	Vibration of the header.	Secure the header. Or set the Sensitivity Switch "L".
	Sensitivity is high.	Set the Sensitivity Switch "L".
	Waterdrops on detection window.	Install in a place keeping the waterdrops off. OR use a rain-cover (Optional).
	Detection area has interfered the area of another sensor.	Set the different frequency position each other.
	The detection 1st row spots are overlapping with the door / header.	Adjust the detection area to deep (outside).
	There is a reflected object in the detection area. Solar light reflects.	Remove the object.
	There was a puddle left by rain or snow. The floor has gotten wet.	This sensor is equipped with the anti-malfunction. However, pay attention when installing as malfunction may occur under the left conditions.
Door stay open or closed	The exhaust of the car and the fog penetrate into the detection area.	
	Presence timer is Infinity. There was an abrupt condition change in the detection area.	Turn the power off and on again.

Contact your installer or the sales engineer if:

- you need to change the settings or replace the sensor.
- the trouble still persists after checking and remedying as described above.



**OPTEx CO., LTD.** (ISO 9001 Certified by LRQA)  
5-8-12 Ogoto Otsu 520-0101, Japan  
TEL: +81 (0)77-579-8700 FAX: +81 (0)77-579-7030  
WEBSITE: www.optex.co.jp

**Optex Incorporated**  
1845 W. 205th Street Torrance, CA 90501-1510, USA  
TEL: (310) 533-1500 FAX: (310) 533-5910  
TOLL-FREE: 800-966-7839  
WEBSITE: www.optexentrances.com

**Secumatic b.v.**  
Tiber 2, 2491, DH The Hague, P.O. Box 24009 2490, AA The Hague  
The Netherlands  
TEL: +31 (0)70 419 41 00 FAX: +31 (0)70 317 73 21  
E-MAIL: info@secumatic.nl WEBSITE: www.secumatic.nl