

MANUFACTURE'S STATEMENT

Read this Operation Manual carefully before use to ensure proper operation of this OPTEX sensor. Failure to read this Operation Manual may cause improper sensor operation and may result in serious injury or death. The meaning of the symbols are as follows : Please study the following first and then read the contents of this manual.

WARNING	Disregard of warning may cause the improper use causing death or serious injury of person.
CAUTION	Disregard of caution may cause the improper use causing injury of person or damage to object.
NOTE	Special attention to section of this symbol is required.
i	It is required to check the operation manual if this symbol is shown on the product.

- NOTE**
- This product is a non-contact presence switch intended for mounting on the header of an automatic door or on the wall. Do not use for any other applications. This sensor cannot be used for industrial doors or shutters otherwise proper operation and safety cannot be guaranteed.
 - When setting the sensor's detection area, make sure there is no traffic around the installation site.
 - Before turning the power on, check the wiring to prevent damage or malfunction of equipment that is connected to the sensor.
 - Only use the sensor as specified in the Operation Manual provided.
 - Be sure to install the sensor in accordance with the local laws and standards of your country.
 - Before leaving the jobsite make sure that the sensor is operating properly and instruct the building owner/operator on proper operation of the door and this sensor.
 - The sensor setting can only be changed by an authorized and instructed engineer. When changed, register the changed setting and dates in the maintenance logbook accompanying the door.

WARNING	Do not wash, disassemble, rebuild or repair the sensor by yourself otherwise it may cause electric shock or breakdown of the sensor.
Danger of electric shock.	

SPECIFICATIONS

Model : OA-FUSION I / II	Relay Hold Time : 0.5sec
Cover color : Black / Silver	Response Time : <0.3sec
Mounting Height : 2.0m to 3.0m	Operating Temperature : -20 to +55°C
Detection Area : See "Adjustment"	Operating Humidity : <80%
Detection Method : Active Infrared Reflection	Protection Grade : IP44
Detection Angle : -5° to 5°	Category : 2 (ISO13849-2)
Adjustments	Weight : 240g
Power Supply : 12 to 24V AC	Accessories : 1 Cable 3m
12 to 30V DC	(10 x 0.09mm ² AWG28)
Power Consumption : <3VA, <150mA (12V DC)	1 Operation Manual
Indicator : Green / Stand-by	2 Mounting Screws
Red / Detection Active	1 Mounting Template
Safety / Test Output : Opto coupler (NPN)	2 M4 Mounting Screws
Active Low / Active High	

NOTE The specifications herein are subject to change without prior notice due to improvements.

- 2**
- Affix the mounting template to the mounting surface.
- NOTE** The sensor mounting position may be limited depending on the header thickness and the mounting height. Make sure that you affix the mounting template as described in the chart. Otherwise, it can be dangerous since there may be no presence detection area around the threshold. Install the sensor as low as possible on the header.

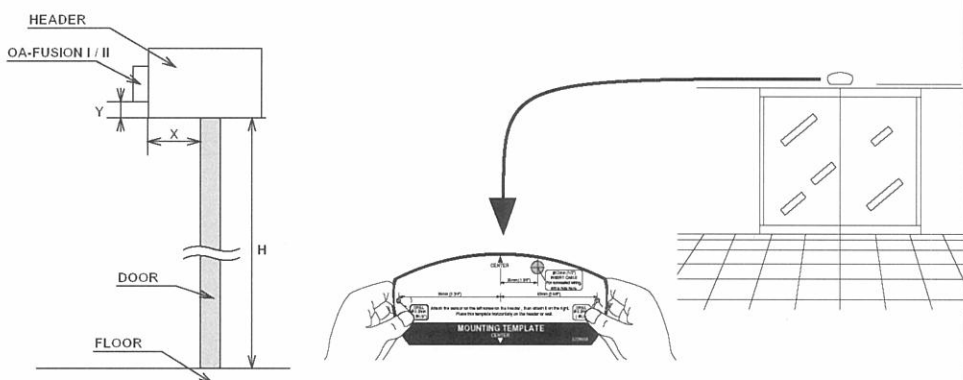

Required Mounting Distance

Distance Between the bottom of the header and the door and the mounting surface (X)	Height from the floor to the bottom of the header (H)			
	2000 (6' 6 3/4")	2200 (7' 2 5/8")	2500 (8' 2 7/16")	3000 (9' 10 1/8")
0	No limit up to 3000mm from the floor	No limit up to 3000mm from the floor	No limit up to 3000mm from the floor	No limit up to 3000mm from the floor
50 (1 15/16")	45 (1 3/4")	50 (1 15/16")	55 (2 3/16")	70 (2 3/4")
100 (3 15/16")	35 (1 3/8")	40 (1 9/16")	45 (1 3/4")	55 (2 3/16")
150 (5 7/8")	25 (1")	30 (1 3/16")	35 (1 3/8")	40 (1 9/16")
200 (7 7/8")	15 (9/16")	20 (13/16")	25 (1")	35 (1 3/8")
250 (9 13/16")	-	15 (9/16")	20 (13/16")	25 (1")
300 (11 13/16")	-	-	-	15 (9/16")

- NOTE** To comply with DIN18650, ensure that the sensor is installed as described above or within smaller value.
- Drill two mounting holes of $\phi 3.2\text{mm}$ ($\phi 1/8"$).
 - To pass the cable through to the header, drill a wiring hole of $\phi 12\text{mm}$ ($\phi 1/2"$).
- NOTE** Be sure that the mounting height does not exceed 3000mm (9' 10 1/8").
- After drilling the hole, remove the Mounting Template.

- 3**
- Wired the cable to the door controller properly as shown in the drawing.

WARNING	Before starting the procedure, ensure that the power is turned off.
Danger of electric shock.	
CAUTION	When passing through the cable to the hole, make sure not to tear the shield otherwise it may cause electric shock or breakdown of the sensor.
Risk of breaking the sensor.	

OUTER DIMENSIONS

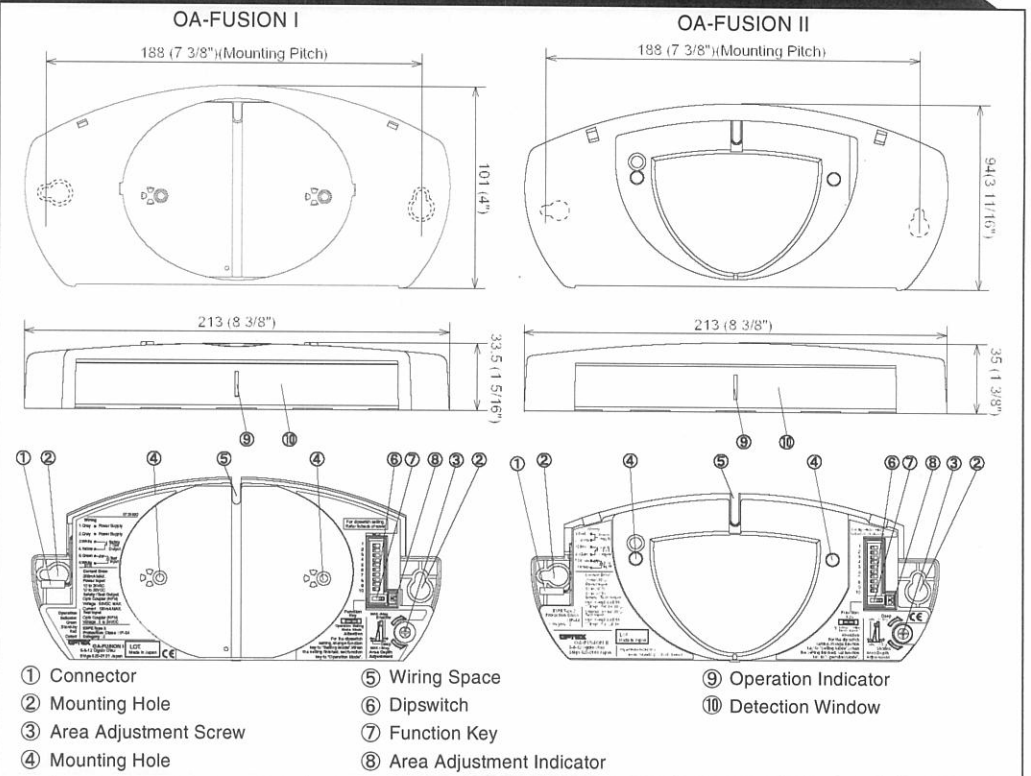

INSTALLATION

- NOTE** The following conditions are not suitable for the sensor installation.
- Existences of smoke and exhaust emission.
 - Wet floor conditions.
 - Vibrating header or mounting surface.
 - Swaying objects or a heating radiator in the detection area.
 - Highly reflecting floor or the presence of highly reflecting objects in the detection area or nearby.



OA-FUSION I shall be used in combination with OPTEX EZ/EZ+, OA-FUSION II shall be used in combination with other activation sensors. For the installation instruction of the activation sensors, refer to the operation manual of the sensor.

For new installation of OA-FUSION I / II and EZ/EZ+, follow the procedures from chapter "2".
For the installation of OA-FUSION I / II on already installed EZ/EZ+, follow the procedures from chapter "1".
EZ/EZ+ : For EZ/EZ+ (See EZ/EZ+ operation manual for the further instructions.)

- 1**
- Turn the power off.
 - Disconnect the EZ/EZ+ wiring.
 - Remove the cover.
 - Disconnect the wires on the EZ/EZ+ terminal block.
 - Remove EZ/EZ+.

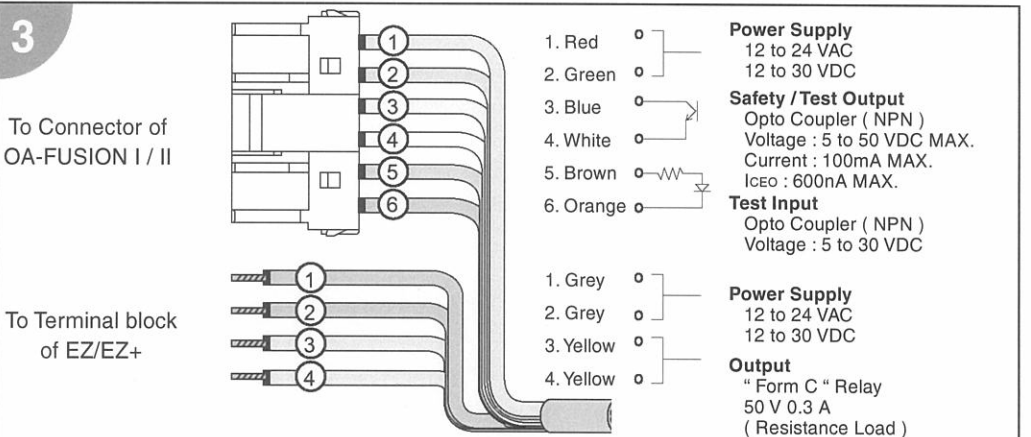

2. Pass the cable through the wiring hole.
- 4**
- Remove the housing cover and attach OA-FUSION I / II to the mounting surface with two Mounting Screws.
 - Remove the housing cover of EZ/EZ+ and attach EZ/EZ+ main body to OA-FUSION I / II with two EZ/EZ+ mounting screws.

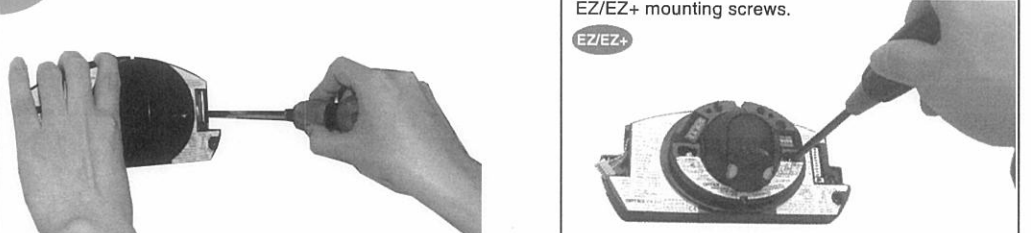

- 5**
- Plug the connector of OA-FUSION I / II.
 - Supply power to OA-FUSION I / II . Adjust the detection area and set the Dipswitches. (See "ADJUSTMENT")
- NOTE** Make sure that you connect the cable correctly to the door controller before turning the power on.
- NOTE** When the power is turned on the automatic learning cycle of 5 seconds starts.
- NOTE** Do not enter the detection area during the learning cycle.
- NOTE** Do not touch the Dipswitch before turning the power on, otherwise an error occurs.
- EZ/EZ+**
- Wire EZ/EZ+.
 - Supply power to EZ/EZ+. Adjust the detection area and select the Dipswitch settings.

- 6**
- Place the housing cover of OA-FUSION I / II. If wiring is to be exposed, break the knockout.
 - Place the housing cover of EZ/EZ+.
-

ADJUSTMENT

1 Detection Area

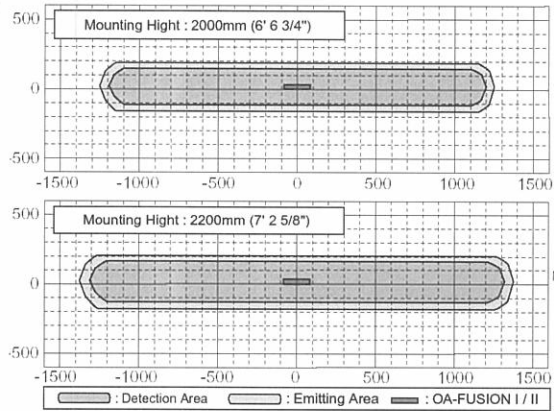

Sensor Setting
 Area Angle : 0°
 Sensitivity : "Mid"
 Area Width : 8 Spots

Test Conditions
 Floor : Grey (Reflection <20%)
 Detection Object : DIN 18650
 Test Body (Mat black)
 Speed of detection object : 50mm / sec

- NOTE** The actual detection area may become smaller depending on the ambient light, the colour / material of an object or the floor as well as the entry speed of an object.
- NOTE** The sensor may not be activated when the entering speed of an object or a person is lower 50mm/sec and higher 1500mm/sec.

2 Area Angle Adjustment

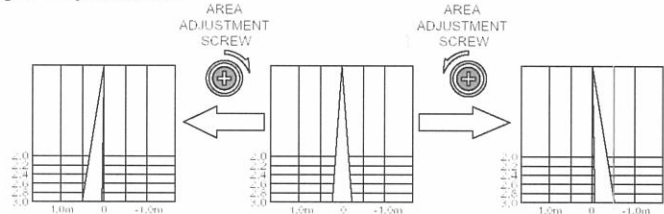

The infrared emitting area can be adjusted up to 5° away from the door (deep) or 5° towards the door (shallow). Adjust the required emitting area by turning the Area Adjustment Screw with a screw driver. Check the area position with Red LED of the operation indicator using a tool such as a reflecting mirror. The use of an INFRARED FINDER (separately available) provides an easy way of adjusting. See the instruction for INFRARED FINDER below.

- Turn the Area Adjustment Screw to the right (deep) to place the area most away from the door.
- Set the sensitivity of the INFRARED FINDER "H (high)" and place it on the floor as shown below.

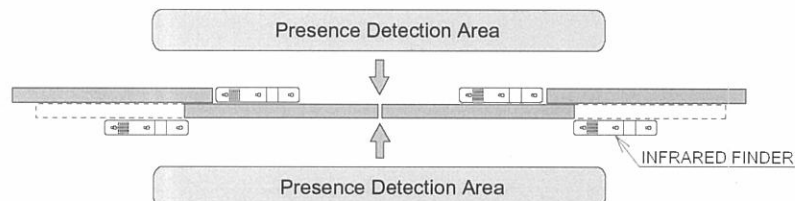

- Turn the Area Adjustment Screw to the left (shallow) until the detection area is placed at the position where INFRARED FINDER is in the low detection status (slow Red LED blinking).
- For the compliance with DIN18650, the further fine adjustment applying the DIN18650 test condition is recommended.

NOTE Make sure the detection area does not overlap with the door / header, otherwise ghosting / signal saturation may occur.

NOTE Do not place a strong reflecting object in the detection area, otherwise signal saturation may occur.

4 Adjustment Example

For the most suitable adjustment and setting to your installation environment, use the chart below for your reference.

Floor Condition		Mounting Height [mm (inch)]				For Example
		2000 (6' 6 3/4")	2200 (7' 2 5/8")	2500 (8' 2 7/16")	3000 (9' 10 1/8")	
Low Reflection Floor	Middle	Middle	High	Super High	-Carpet -Dark Colour Floor	
Middle Reflection Floor	Low	Middle	Middle	Super High	-Concrete	
High Reflection Floor	Low	Low	Middle	High	-Tile -Marble	

NOTE Special attention to the setting is required when the door is used often by the elderly or children. e.g. When the elderly often pass the door set the presence timer "Infinity". When the children often pass the door set the sensitivity higher than usual. Please adjust the sensitivity and presence detection timer according to your risk assessment.

CHECKING

Check the operation according to the chart below.

Entry Motion	Power Off	Outside the Detection Area	Entry into the Detection Area	Outside the Detection Area
Image				
Sensor Status	Power Off	Stand-by	Presence Detection Active	Stand-by
Operation Indicator	-	Green	Red	Green
Output (Active Low)	-			
Output (Active High)	-			

INFORM BUILDING OWNER / OPERATOR OF THE FOLLOWING ITEMS

- When turning the power on, always walk-test the detection area to ensure proper operation.
- Always keep the detection window clean. If dirty, wipe the detection window with a damp cloth. (Do not use any cleaner or solvent.)
- Do not wash the sensor with water.
- Do not disassemble, rebuild or repair the sensor yourself otherwise electric shock may occur.
- Always contact your installer or service engineer when adjusting the settings.
- Do not place an object that moves or emits light in the detection area. (e.g. Plant, illumination, etc.)
- Do not paint the detection window.

3 If the error (twice green blinking) occurred, follow the steps below.

Set Function Key to "Setting Mode" and change Dipswitch 10 setting (on→off, off→on) and set Function Key to Operation Mode.

Setting of Dipswitch

- Change the Function Key from "Operation Mode" to "Setting Mode".
- Change the Dipswitch setting.
- Change the Function Key back to "Operation Mode".

Operation Mode

Setting Mode

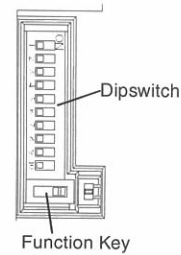

Setting the Sensitivity

Normally set to "Mid". "Low" decreases the sensitivity and "High / S-High" increases the sensitivity.



Setting the Presence timer

The presence timer can be selected from following 4 settings. To comply with DIN18650, set the presence timer to "60sec." or longer.



Adjusting the Area Width

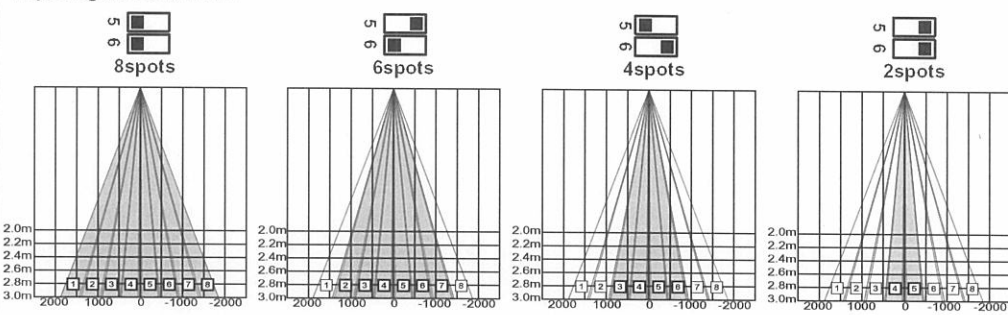

NOTE The actual detection area may become smaller depending on the ambient light, the colour / material of object and the floor as well as the entry speed of object.

Setting the Frequency Function (Interference Prevention)

When using more than two sensors close to each other change the interference switch setting. Two different frequencies can be selected by Dipswitch 7.

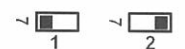

Setting the Safety / Test Output

Safety / Test Output to the door can be selected between "High" and "Low" with Dipswitch 8.

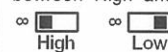

Setting the Test Input

Select the Test Input from the door to the sensor "High" or "Low" by Dipswitch 9.



Setting the Test Input Delay Time

The delay time between the test input and test output is either 10mSec. or 20mSec. selectable by Dipswitch 10.

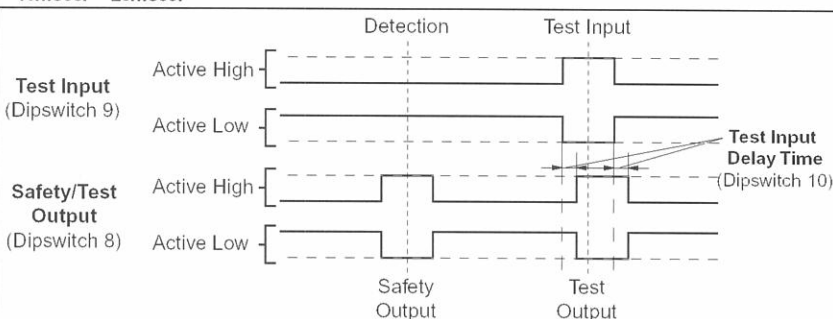

NOTE When the door remains opened after adjustment hard-reset the sensor.

COMPLIED STANDARDS

DIN 18650-1:2005	EN 954-1:1997
DIN 18650-2:2005	ISO13849-2:2003
EN 12978:2003	prEN 12650-1:1999
EN 614-3:2001	prEN 12650-2:1999

TROUBLE SHOOTING

Trouble	Operation Indicator	Possible Cause	Solution
Does not operate	No LED	Power supply is not adequate.	Adjust to the stated voltage.
	Green (Fast Blinking)	Connection Failure	Check the wiring and the connector
		Self Monitoring detection.	Contact your installer or the service engineer.
	Green (Slow Blinking)	Signal Saturation	Set the Sensitivity Switch "Low". Or remove highly reflecting object from the detection area.
		Dirty detection window	Wipe the detection window with a damp cloth. (Do not use any cleaner or solvent.)
		Sensitivity is insufficient.	Set the Sensitivity Switch higher
Green (Twice Blinking)	The detection area is overlapping with the header.	Adjust the detection area to "deep" (outside).	
	Wrong setting of Dipswitch	Follow "3 Setting of DipSwitch".	
Operates itself (Ghosting)	LED Unstable	There is an object that moves or emits light in the detection area. (Ex. Plant, illumination, etc.)	Remove the object.
		Vibration of the header.	Secure the header. Or set the Sensitivity Switch "Low".
	Sensitivity is too high.	Set the Sensitivity Switch "Low".	
	Water drops on detection window.	Install in a place keeping the waterdrops off.	
	The Detection area is overlapping with the area of another sensor.	Set the different frequencies from each other.	
	The detection area is overlapping with the door / header.	Adjust the detection area to "deep" (outside).	
Door stays open	LED red	There is a reflecting object in the detection area. Or Light is reflecting on the floor.	Remove the object.
		There is a puddle after rain or snow. Or the floor is wet.	Check the installation condition referring to "INSTALLATION" on the reverse side.
		The exhaust of the car and fog penetrate into the detection area.	Set Presence Timer again. Follow "3 Setting of DipSwitch". If the problem still persists, hard-reset the sensor. (Turn the power OFF and ON again).
No output	LED Unstable	Wrong wiring	Check the wiring for output.

Contact your installer or the service engineer if the trouble still persists after checking and remedying as described above.

OPTEX CO.,LTD.
 (ISO 9001 Certified by LRQA)
 5-8-12 Ogoto Otsu 520-0101, Japan
 TEL.: +81 (0)77-579-8700
 FAX.: +81 (0)77-579-7030
 WEBSITE : www.optex.co.jp

Optex Technologies, Inc.
 3882 Del Amo Blvd., Suite 604
 Torrance, California 90503 USA
 TEL.: +1(310) 214-8644
 FAX.: +1(310) 214-8655
 TOLL-FREE : +1(800) 877-6656
 WEBSITE: www.optextrances.com

Secumatic b.v.
 Tiber 2. 2491, DH The Hague,
 P.O. Box 24009 2490 AA The Hague
 The Netherlands
 TEL.: +31 (0)70 419 41 00
 FAX.: +31 (0)70 317 73 21
 E-MAIL: info@secumatic.nl
 WEBSITE: www.secumatic.nl