

COMBINED RADAR OPENING AND ACTIVE INFRARED SAFETY SENSOR

1

DESCRIPTION

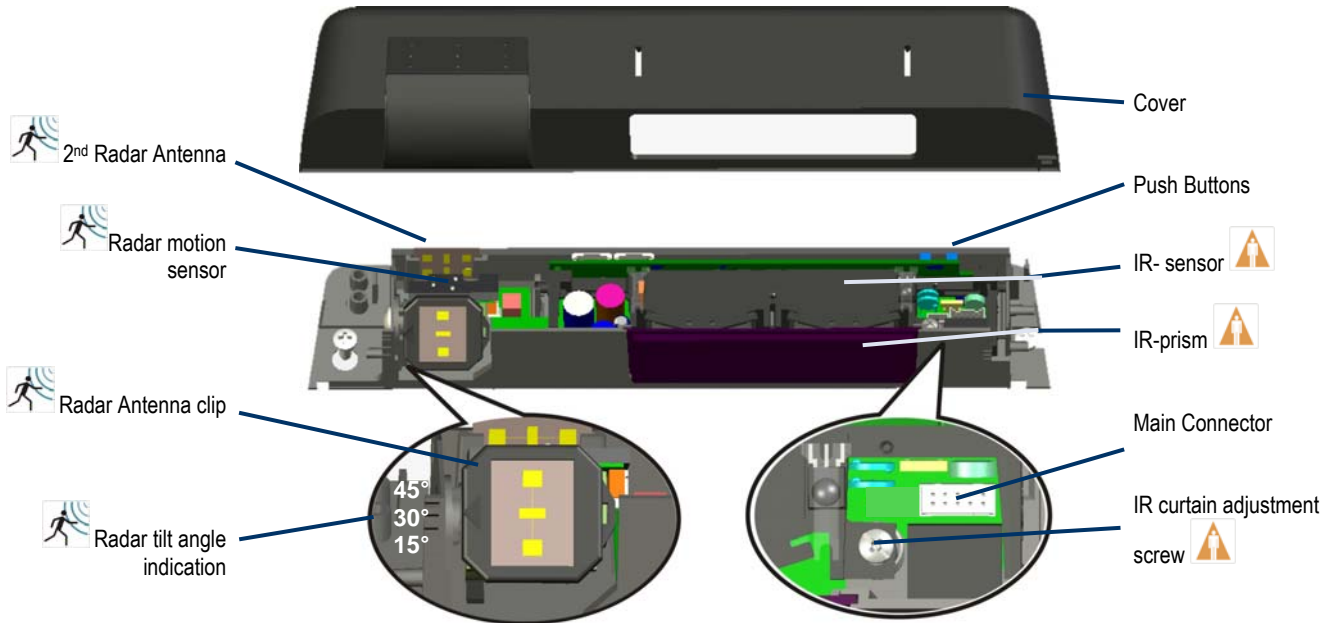

2

SYMBOLS AND LED

LED turns on	LED flashing slowly	LED flashing quickly	Motion detection	Presence detection	See page x	Factory value
LED display during normal function						
	GREEN LED	Motion detection				
	RED LED	Presence detection				
	ORANGE LED	Troubleshooting				

3

INSTALLATION

Use the Remote Control to adjust the sensor.	Use the Spotfinder to locate the safety curtains.	Insert the prism correctly into the guiding grooves!	Make sure the door controller cover is fixed properly and electrically earthed.	Avoid touching electronic and/or optical parts!
Avoid vibrations!	Do not cover the sensor!	Avoid moving objects in proximity to the sensor!	Avoid HF lamps and fluorescent lighting in the infrared field!	Avoid highly reflective objects in the infrared field!

1 Mounting the sensor



Mount the sensor at a maximum height of 5 cm from the bottom line of the door controller.



Use the mounting template to drill holes and position the sensor.

2 Wiring the sensor

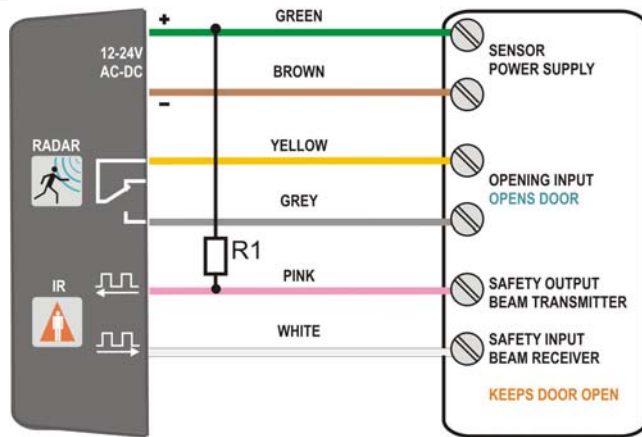

$R1 \leq 470\Omega$

(Note: check that the door operator is compatible with this value)

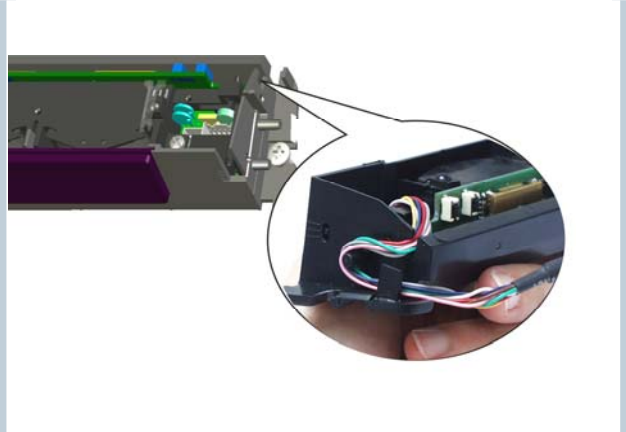

To ensure waterproof installation, place the cable as shown above.

3 Width of radar motion sensing field: choice of antenna

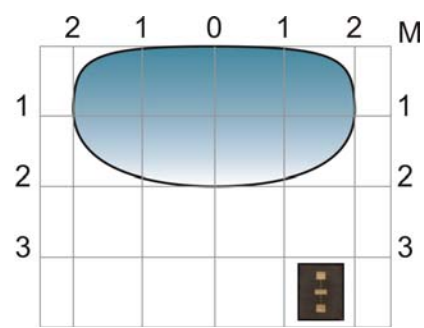

Sensitivity = 9

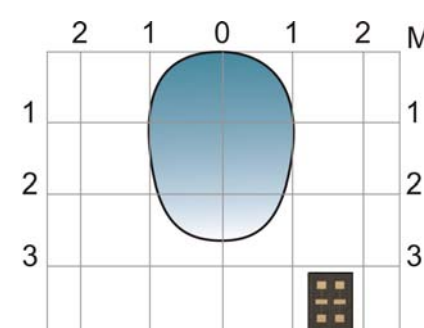

Sensitivity = 9



Touching the antenna patches will not cause any damage!

4 Depth of radar motion sensing field: tilt angle of radar-module

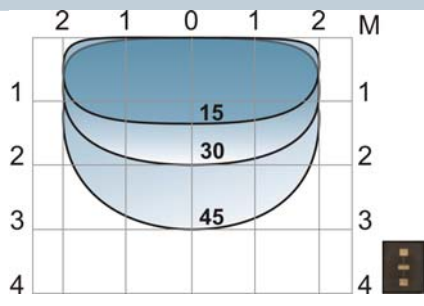

Sensitivity = 9

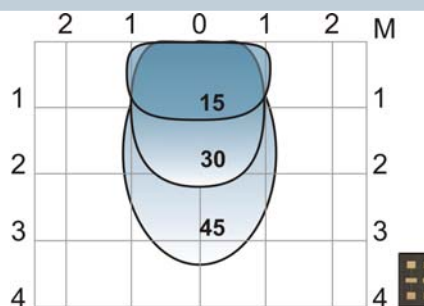

Sensitivity = 9

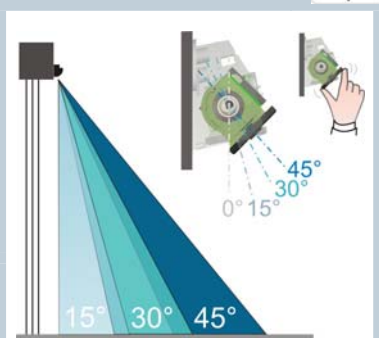

5

Width of IR presence sensing field: choice of prism

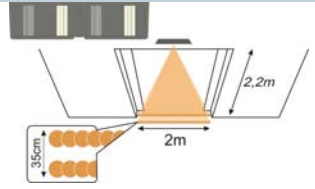

2 curtains of 24 overlapping spots (no gaps)

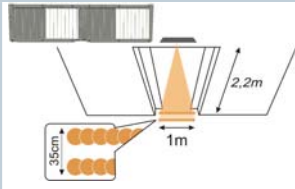

2 curtains of 12 overlapping spots (no gaps)



Make sure to introduce the prism into the guiding grooves in front of the lenses and not into the cover!

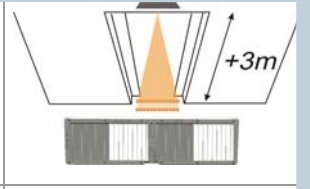

If installed at a mounting height of 3 m or more, use the narrow prism.

6

Depth of IR presence sensing field: angle of IR-module (negative angle available)

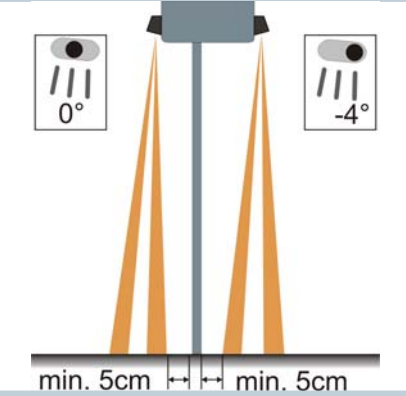

Keep a minimum distance of 5cm between the door and first curtain.

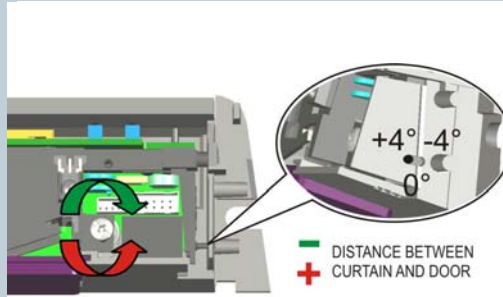

To reduce the distance between curtain and door, turn the screw clockwise. To increase the distance, turn the screw counterclockwise. The pin indicates the angle.











Use the Spotfinder to locate and adjust the position of the curtains.







When mounting one sensor on each side of the door above a highly reflective threshold, select different frequencies to avoid crosstalk between the sensors.

5

7.2 Launching a setup

Unlock the sensor to enter into adjustment session.			
To launch an assisted setup → recommended after mechanical adjustments of the IR sensor module. → recommended once after the first installation			
	This setup is only effective if the relay output (opening) has been wired to the door controllers opening impulse input. This is required to create a door opening/closing cycle.		The sensor performs a door opening and closing cycle to check the influence of the door leaves to the safety curtains. See Troubleshooting if RED LED flashes quickly after setup.
To launch a setup → recommended after change of parameters by remote control			
			The sensor only takes a new reference picture.

LED display during sensor assisted setup



Setup process active:	After finishing the setup process, the sensor shows the following behaviour:		
 RED/GREEN LED alternating		RED LED flashing quickly	The sensor 'sees' the door movement and can not finish its setup.
		RED LED continuously on	The sensor signals a faulty IR monitoring. 
		ORANGE LED continuously on	The sensor encounters signal saturation (ex. due to highly reflective floor). 
		No LED turns on	The sensor successfully finished its setup.

7.3 Additional remote control adjustments

F1 SAFETY OUTPUT REDIRECTION 



0 no redirection
1 transfer presence detection to motion output
2 motion output only activated if motion and presence detection

0

 **HOLD TIME** 



0-9 0 (0.5s) > 9 (9s)

0

 **DETECTION MODE** 

1 bidirectional mode
2 unidirectional mode
3 unidirectional mode with MTF
4 unidirectional mode REVERSE

2

 **IMMUNITY** 

1 detection of quasi presence
2 normal
3 increased
4-9 additional increased immunities

2

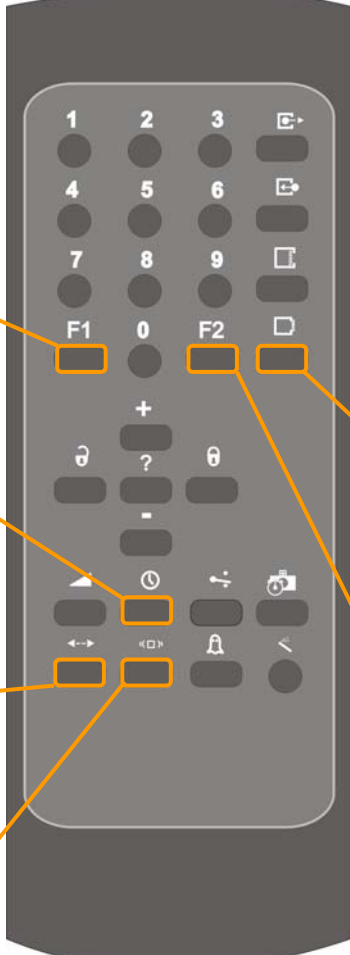

 **INSTALLATION CONFIGURATION**

	MOUNTING HEIGHT	PULSE FREQUENCY
1	low	low
2	high	low
3	low	high
4	high	high

1

F2 DOOR CONTROL

1 normal (LED in normal mode)
2 door permanently open (red LED ON)
3 door permanently closed (red LED OFF)

1

TÜV Requirements in Germany



To be TÜV compliant for the German market, please make sure to adjust the sensor as follows:

	Number of IR curtains	2
	Max. duration of presence detection	1 or higher (min. 1minute)
	IR curtain immunity	1 to 3

High mounting height (>3m)

If the sensor is installed higher than 3m above the floor, make sure to use the narrow prism. In addition set the mounting height to "high mounting":

3+5

	2	Installation Configuration	High Mounting Height
	4	Installation Configuration	High Mounting Height

Inside installation



According to the location and use of the sensor, choose one of the following presettings:

	1	Presetting 1	Internal installation, vulnerable users	
	2	Presetting 2	Internal installation, normal or trained users	
	3	Presetting 3	External installation, vulnerable users	
	4	Presetting 4	External installation, normal or trained users	

Outside installation



Rain/Snow



If the sensor is exposed to rain or snow, use the URC (Universal Rain Cover). Set the sensor to presetting 3 or 4 to increase the immunity of the sensor. You can reduce the influence of rain and snow even more when selecting the RAIN or SNOW mode for the IR curtain immunity:

4

	3	RAIN mode	
	4	SNOW mode	
	5	SNOW mode enhanced	

Reflective environments

The additional increased radar immunity modes (4-9) reduce disturbances of the motion sensor in highly reflective environments (airlocks, curved and round sliding doors, metallic environments etc.).

5

	4-9	Additional increased immunities
--	-----	---------------------------------

Setup

	0	Assisted Setup (~14sec)	Sensor checks the influence of the door leaves on the IR curtains (performs a door open/door close cycle)	
		Standard Setup (~4sec)	Sensor only learns its environment	

5

After adjusting the sensor for the first time, it is recommended to launch an "assisted Setup". If the IR sensor module "sees" the door movement, move the curtains out of the door leaves.

Access Code



The access code is recommended to set sensors that are installed close to each other with remote control. If you forget the access code, you can still gain access to the sensor during the first minute after powering up (unlocking the sensor does not require entering an access code). You can program a new code or remove the code by entering LOCK 0000.

		Save an access code (between 1 and 4 digits)
		Delete the access code (0 or 0000)

Overlapping IR-curtains

Overlapping IR-curtains from sensors installed side-by-side may cause disturbances due to crosstalk. Select different frequencies on each sensor to avoid crosstalk. Attention: avoid curtains that are overlapping by more than 30 cm (at 2,2m, using wide prism).

5

Only one single impulse input on door controller

If your door controller has only one single impulse input for motion impulse (open the door) and no safety input (keep the door open), use the "Safety Output Redirection" to transfer the safety detection (IR sensor module) to the motion impulse output and connect only the motion output to your door controller. Note that the monitoring function is no longer active.















	F1	1	Safety Output Redirection	Transfer presence detection to the motion output
--	----	---	---------------------------	--

Check the wiring



Push the left push button to release the outputs. The door should close and the LED should switch off.

Push Buttons

For more information on the use of the push buttons, ask our quick reference guide "How to use push buttons".









	SYMPTOMS	POSSIBLE CAUSES	CORRECTIVE ACTION	
	Red LED flashing quickly after an assisted setup.	The sensor 'sees' the door movement and can not finish its setup.	Adjust the position of the IR curtains.	3
	Red LED permanently ON after an assisted setup.	The sensor fails the IR test.	1. Cut and restore the power supply. 2. Launch a new assisted setup. If the LED still stays ON, replace the sensor.	5
	Red LED ON	The sensor detects a presence.	Wait as long as the time set in the "maximum duration of presence detection" setting or launch an assisted setup (with the remote control or right push button).	4-5
	Red LED ON The presence detection is disturbed by the rain.		Increase the immunity of the curtains (value 3 - 5)	4
	Green LED ON The radar detection is disturbed by the rain.		1. Check whether the unidirectional mode is selected and the MTF function is disabled. 2. Increase the radar immunity.	5
	Orange LED flashes	The sensor signals an internal fault.	Cut and restore the power supply. If the orange LED flashes again, replace faulty sensor.	
	Orange LED ON	The sensor encounters signal saturation.	1. Use the wide field prism and/or slightly increase the IR-curtains angle (turning the screw counterclockwise). 2. Launch an assisted setup.	3+5
	The door is not closing. LED OFF	1. On-Off switch at door control is in wrong position or is faulty. 2. Improper output configuration on the sensor.	Check to insure that On-Off switch for door is in ON or AUTOMATIC position. Check the output configuration setting on each sensor.	4
		3. Faulty sensor monitoring of the door controller.	1. Check if the monitoring mode is ON or PULSE depending on the door controller. 2. Check the wiring. 3. Verify that 'Door Control' (F2) is set to 'AUTO'.	3+5
	The door closes slowly. LED OFF	Faulty sensor monitoring of the door controller.	1. Check if the monitoring mode is ON or PULSE depending on the door controller. 2. Check the wiring. 3. Verify that 'Door Control' (F2) is set to 'AUTO'.	3+5
	After a power on, there is no LED-signal, even during a motion detection. The motion output is active and the presence output is fixed.	The sensor's monitoring input is not correctly supplied.	Check the wiring and the power supply (voltage and polarity) of the monitoring input. Disable the monitoring of the sensor if the door controller cannot monitor the sensor.	3+5
 	Door keeps recycling open-closed.	The sensor is disturbed by the door motion because it sees the door or feels vibrations.	Green LED signals motion detection: Increase radar angle and radar immunity. Red LED signals infrared detection: Increase IR curtains angle (turning the screw counterclockwise).	2+3
	In airlock vestibules, the sensor sees the opposite door.	.	Increase radar immunity.	
	In metallic environments, the sensor detects objects outside of its detection field.		Increase radar immunity.	
	Unwanted presence detection	1. The sensor is not placed properly. 2. The front face is not properly fixed.	Fasten the sensor firmly. Check whether the front face prism is placed into the guiding grooves and not in the sensor cover.	3
	The sensor does not respond to the remote control.	1. Batteries in the remote control are not installed properly or dead. 2. Remote control badly pointed.	Verify whether the batteries are installed correctly or replace batteries. Point the remote control towards the sensor.	
	The sensor does not unlock when access code is entered.	Wrong code being entered.	Cut and restore power supply. No code is required to unlock during the first minute after powering. Press on "unlock", then on "lock" and introduce a new access code.	6

Supply voltage	: 12V (-5%) to 24V (+10%) AC/DC
Mains frequency	: 50 - 60 Hz
Power consumption	: < 3 W
Mounting height	: 1.8m to 4m
3-coloured LED	: RED (presence detection) - GREEN (motion detection) - ORANGE (signal saturation, error)
Temperature range	: -25°C to +55°C
Degree of protection	: IP54
Norm conformity	: R&TTE 1999/5/EC; EMC 89/336/EEC
Dimensions	: 262 mm (L) x 55 mm (H) x 44 mm (D)
Weight	: 250 g
Housing material	: ABS + LURAN S
Minimum length of cable	: ± 2.6 m
Range of Remote Control	: 5m

	 MOTION SENSOR	 PRESENCE SENSOR																		
Detection mode	Motion Minimum detection speed: 5 cm/s (measured in sensor axis)	Presence Typical response time: < 128 ms (max. 500 ms)																		
Technology	Microwave and microprocessor Transmitter frequency: 24.175 GHz Transmitter radiated power: < 20 dBm EIRP Transmitter power density: < 5 mW/cm ²	Focused active infrared and self-monitored microprocessor Spot diameter (standard): 0.1m max Number of spots: 24 or 12 spots by curtain Number of curtains: 2																		
Detection field	<table border="1"> <thead> <tr> <th></th> <th>Width</th> <th>Depth</th> </tr> </thead> <tbody> <tr> <td>Wide</td> <td>4 m</td> <td>2 m</td> </tr> <tr> <td>Narrow</td> <td>2 m</td> <td>2,5 m</td> </tr> </tbody> </table>		Width	Depth	Wide	4 m	2 m	Narrow	2 m	2,5 m	<table border="1"> <thead> <tr> <th></th> <th>Width</th> <th>Depth</th> </tr> </thead> <tbody> <tr> <td>Wide</td> <td>2 m</td> <td>0,35 m</td> </tr> <tr> <td>Narrow</td> <td>1 m</td> <td>0,35 m</td> </tr> </tbody> </table>		Width	Depth	Wide	2 m	0,35 m	Narrow	1 m	0,35 m
	Width	Depth																		
Wide	4 m	2 m																		
Narrow	2 m	2,5 m																		
	Width	Depth																		
Wide	2 m	0,35 m																		
Narrow	1 m	0,35 m																		
Angle	From 15° to 50° in elevation (adjustable)	From - 4° to + 4° (adjustable)																		
Output specification	Relay (free of potential contact): Max. contact voltage: 42V AC/ DC Max. contact current: 1A (resistive) Max. switching power: 30W (DC) / 60VA (AC)	Transistor (NPN open collector) requiring ext. pull-up resistor Max. output current: 25 mA Max. switching power: 40 V DC Max. pulse amplitude (detection state or fail state): 0,8V																		
Input specification		Input Impedance: 100kΩ Max. input voltage: 30 V DC External pull-up resistor: ≤ 470Ω* Min. Pulse amplitude (Vpp): > 50% of sensor supply voltage Max. Pulse duration: 100µs @ 25mA output current Min. time interval between pulses: > pulse duration *check that the door controller is compatible with this value																		
Output holdtime	0.5s to 9s (adjustable)	0,1/1s (fixed)																		

Sensing field dimensions given at 2.2m mounting height.
Specifications are subject to changes without prior notice.



			
Remote Control	Spotfinder	ACA	ABA
			
Antenna narrow field	Antenna wide field	Prism 1 m	Prism 2 m