

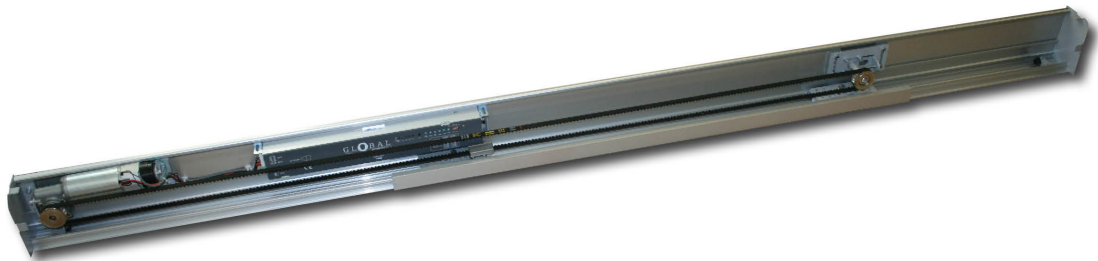

# Technical Manual

## Premier-Slide Compact AIO





## Table of Contents

Page

1.	Front Cover
2.	Table of Contents
3.	Introduction
4.	Parts List
5.	Preparation of Doors
6.	Preparation of Carriage Assemblies
7.	Installation of Track and Door Heights
8.	Installation of Floor Guides
9.	Adjustment of Floor Guides : cont
10.	Hanging & Aligning Doors
11.	Location of Internal Parts
12.	Install of Equipment / Brackets
13.	Assembly of The Belt Brackets
14.	The Mode Switch Connection
15.	Setting Up Procedure
16.	Control Unit Settings
17.	Battery Unit Operation
18.	The Mode Switch Operation Instructions
19.	Connection Board & Wiring Instructions (Generic)
20.	Connection Board & Wiring Instructions (Optex)
21.	Connection Board & Wiring Instructions (Bea)
22.	Connection Board & Wiring Instructions (Hotron)
23.	Fault Finding
24.	Trouble Shooting
25.	Technical Specification



**CAUTION**

**AN INADEQUATELY INSTALLED AND ADJUSTED DOOR COULD CAUSE DAMAGE TO THE EQUIPMENT AND MAY CAUSE INJURY TO OTHERS.**

- HAVE YOUR DOOR PERIODICALLY INSPECTED & SERVICED AT LEAST TWICE PER YEAR BY AN ADSA (*Automatic Door Suppliers Association*) CERTIFIED TECHNICIAN.
- THIS DOOR IS NOT INTENDED TO BE DISCONNECTED FROM THE MAINS AT NIGHT!

**Introduction**

This Manual Contains all the information you require to install, maintain and service your Premier-slide automatic sliding door operator.

The Premier-Slide 253 automatic sliding door system has been designed and refined to create a reliable sliding door system which is simple / fast to install and which has a quick / easy setup procedure.

It uses simple adjustments and LED indicators to show status conditions.

**Safety Standard**

Your door system has been manufactured to the latest applicable safety standard; in order for you to comply you will need to have the door installed to any relevant safety standards by a qualified company. The door will need to comply with the British standard BS: 7036: 1996 as a minimum but may need to comply with other standards such as Part M, Building regulations or Disability Discrimination act. Please consult the relevant professional bodies for details.

**Intended Use**

This operator has been manufactured for Dry use within or inside Weather Tight buildings.

**Main Features :**

- Full microprocessor control with smooth motor control using encoder technology.
- Led indicators to aid fault finding.
- Easy to adjust wheel system.
- “Creep Speed” input.
- Electromagnetic motor lock as standard (Via an on/off via dip switch).
- Fast Installation – minimal tools required.
- Heavy Duty Monitored Battery Backup with single opening .
- Motor direction via dipswitch.
- Slim-line Mode switch with plugged connection cable. (Suitable for frame or wall fixing).

1. Motor Gearbox
2. Microprocessor Control unit
3. Idler Wheel
4. Long belt Clamp
5. Short belt Clamp
6. Carriage Wheel Assembly
7. Heavy Duty Toothed Drive Belt
8. Mode Switch
9. End Stop
10. Track Extrusion
11. Canopy Extrusion
12. L/H Operator End Plate
13. R/H Operator End Plate

**Extrusion**

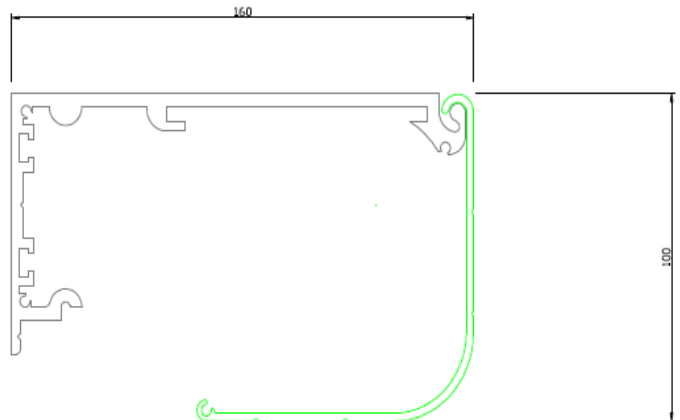

## **Preparation of Doors**

The door operator kit is supplied with an aluminium adaptor rail which needs to be fitted in the top to the door leaf. This adaptor allows the “door hanging brackets” to be easily attached to the door leaf. This should be cut the full internal width of the door leaves.

Sufficient fixings / re-enforcement must be installed to carry the weight of the door leaf.

If a new door leaf is to be supplied, then suitable re-enforcement should be added during manufacture.

We recommend a minimum thickness of 5mm aluminium bar. This should be installed inside the top door rail. (see Fig 1/2)

If the unit is to be fitted to an existing door (see Fig 2), then a suitable fixing such as a “threaded insert” should be used. The top of the door rail will need to be in-filled with a suitable material and the adaptor rail would need to be finished the same as the door leaves.

### **Never rely on just tapped threads in an aluminum door.**

The adaptor can be fitted into the top door rail if space allows or it can be fitted flush on the top (using suitable packing if required).

If the adaptor rail is being fitted into the top of the door rail, then remember to insert the steel threaded plates into the adaptor rail before it is fitted to the door. It requires 4 x fixing plates per door leaf.

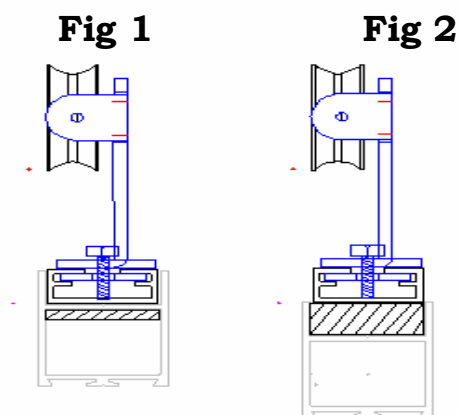

Once the adaptor rail has been installed on the door leaf, then the “Door Hanging” brackets can be fitted to the adaptor, using the M8 x 30mm hex head bolts fitted to the steel threaded fixing plates.

The door hanging brackets have slots to allow the door distance from the frame, to be adjusted as ness.

Position the hanger brackets so that the centre of the bracket is 150mm from the edge of the door.

Once the door is suitably located and adjusted, ensure all M8 bolts are fully tightened.

For Door leafs wider than 1150mm we would recommend an additional Carriage assembly per leaf.

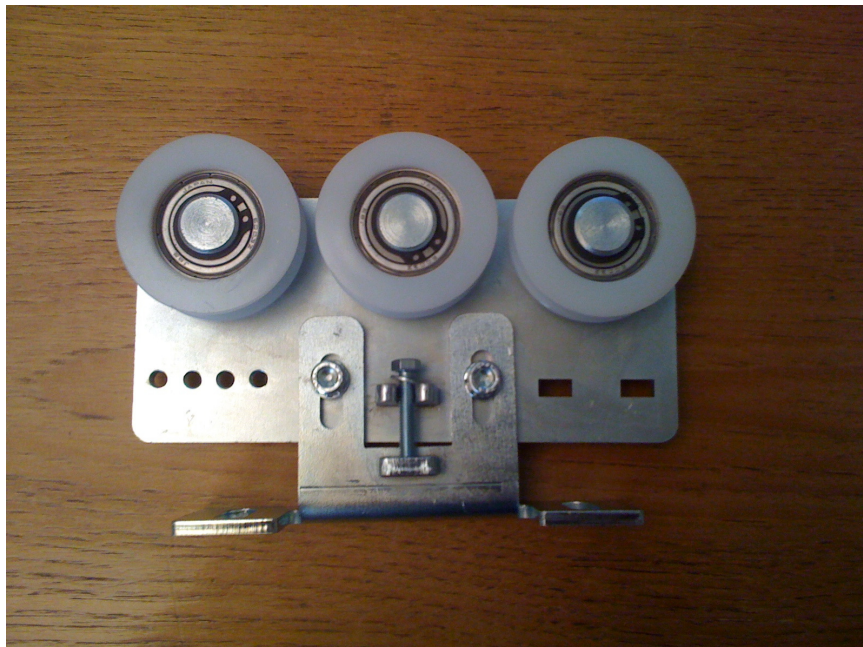

### Installation of Track System

#### Always work in pairs.

- The track system comprises an aluminum track section and a hinged / removable cover.  
*(Please note: Sometimes there can be a slight bend to the length of long track extrusion but this is easily removed by fixing from one end and straightening it up as you go). Being made from aluminium the track has a certain amount of flexibility.*
- The Header is mounted either on framework or on the area above the doorway, which should always be checked to ensure a suitable fixing can be obtained to carry the imposed weight of the proposed door leaf/s.
- Align the Header on the fitting section 20mm up from clear opening height and Level. Mark through one of the bottom fitting holes at each end. Remove the header, drill tap and Fix the Unit up.
- Attention should be paid to what fixings are used when fitting in the area the wheels roll past. Take into consideration wire runs from sensors and Mains spurs.
- Keep the inside of the running track where the wheels run free from dirt and drilling swarf.
- Allow a minimum of 265mm outward for the canopy to be raised for repairs and maintenance.

### TRACK INSTALLATION HEIGHT

**(Flush Adaptor) = Door Leaf + Bottom Gap + 6mm**

**(Surface Mounted) = Door Leaf + Bottom Gap+ 22mm**

### DOOR HEIGHT CALCULATIONS

**(Flush fitted Adaptor Rail) = Clear Opening height - Bottom Gap + 15mm**

**(Surface Mounted Adaptor Rail) = Clear Opening height - Bottom**

## Installation of Floor Guides

The standard floor guide system Available with the Premier-Slide uses a guide track installed into the bottom of the door rail and a floor mounted adjustable guide.

The guide channel is simply cut to the inside dimension of the door leaf and attached using countersunk self tapping screws straight into the door rail. The rear of the door can be notched out (see Fig 5) to allow the guide block to slide in if required.

The same system is used on the secondary leaf, except the floor guide is mounted on a floating bracket that is fixed off of the master leaf(s). See Fig 6a

**Fig 5**

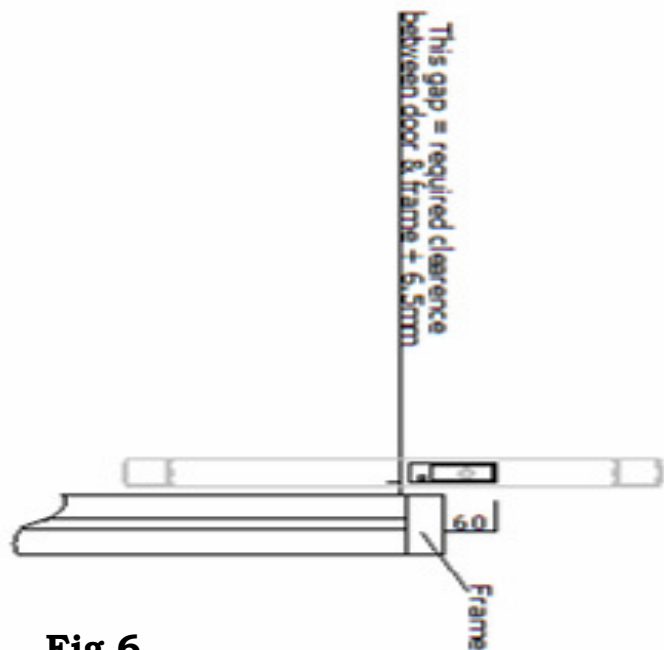
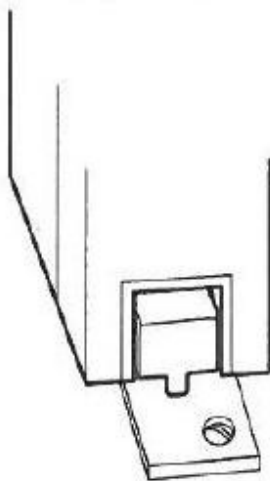

**Fig 6**

The floor mounted guide block assembly is simply drilled into the floor and secured with countersunk screws and rawl plugs

The guide should be positioned so that the side of the floor guide nearest the frame is positioned as follows:

Required clearance gap + 6.5mm from framework and the front of the guide should be approx 60mm into the opening (see Fig 6)

## Adjustment of Floor Guides

The guide itself is adjustable for sideways movement +/- 4mm (see Fig 7)

**Fig 7**

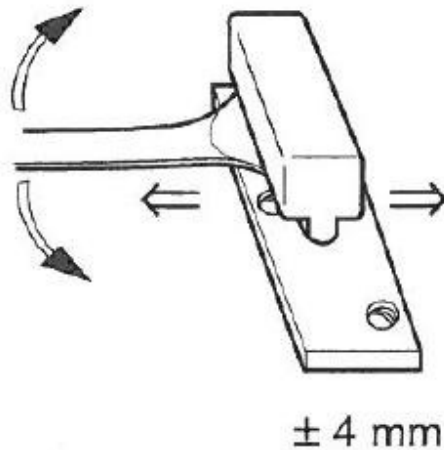

Simply insert a slim 19mm spanner beneath the nylon block and turn either Clockwise or anticlockwise.

As the shaft of the guide is eccentric, the guide will move closer to or away from the frame as the spanner is turned.

## Hanging & Aligning Doors

### Procedure for wheel adjustment:

To Adjust the Doors up and down, loosen the two M6 Bolts. Now you can turn the M5 Adjustment bolt to the left to bring the doors up or to the right to lower them. When the doors are at the correct height simply tighten the two M6 Bolts to secure the Hanging Bracket to the assembly.

This assembly gives you approx 7mm of adjustment in each direction from the centre point.

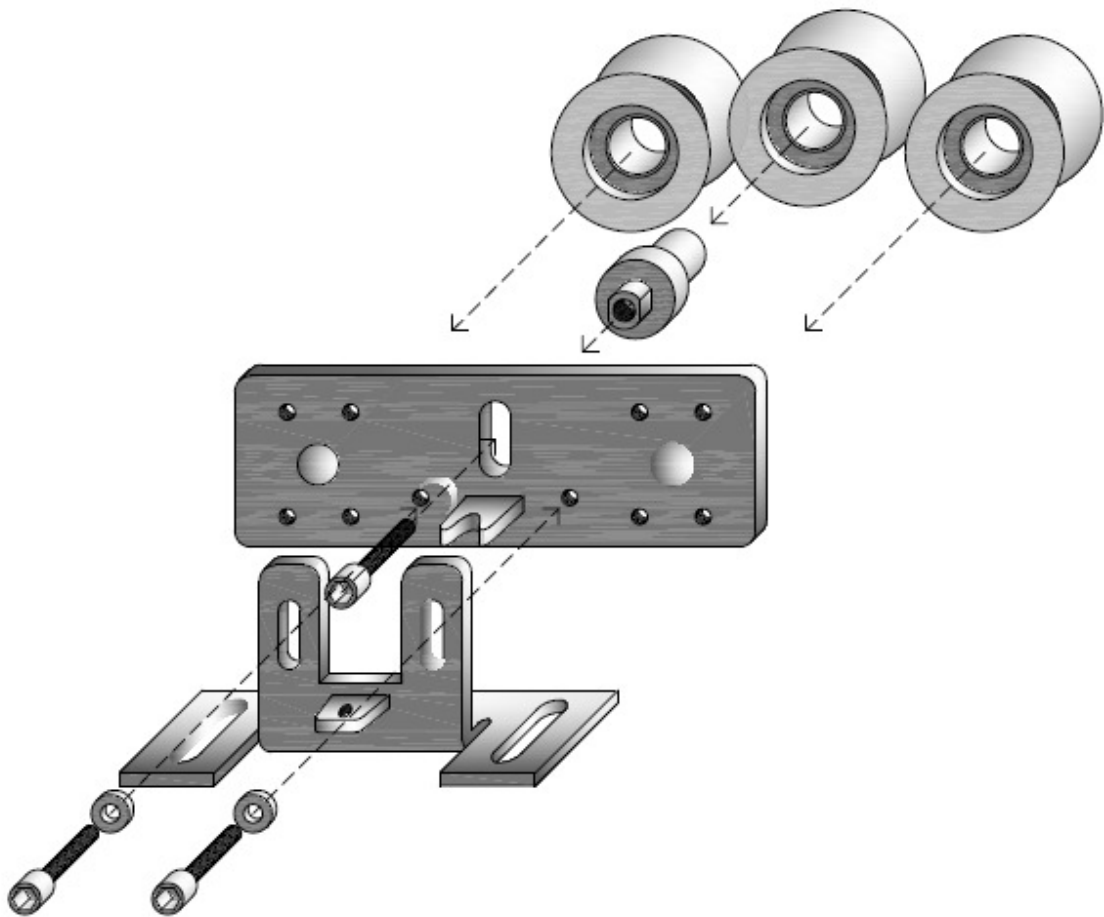

**Location of Internal Parts within a Premier-Slide Door Set**

The Premier-Slide operator is normally supplied fully assembled but can be supplied in kit form. Therefore the following instructions are for either for kit form operators or if you need to remove any of the equipment during its installation.

**Installation of Equipment**

Measure and note the width of a door leaf and then measure from the centre of the door opening (marking at centre) to a length of one & half times the door leaf width to each side ( See A & B in Fig 9) and mark the track with a pencil.

Position the motor/gearbox unit and the idler pulley assembly so that the centre of the pulley wheel on each align with the markings just placed.

Install new control unit to the right hand side of the motor within distance of motor wiring loom and connect motor to the left hand side socket connector.

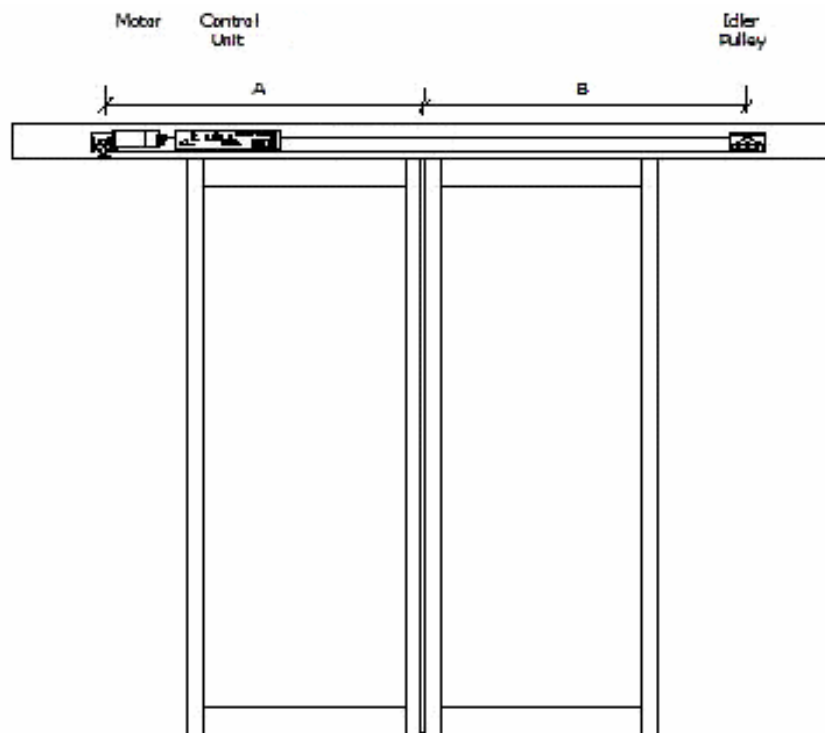

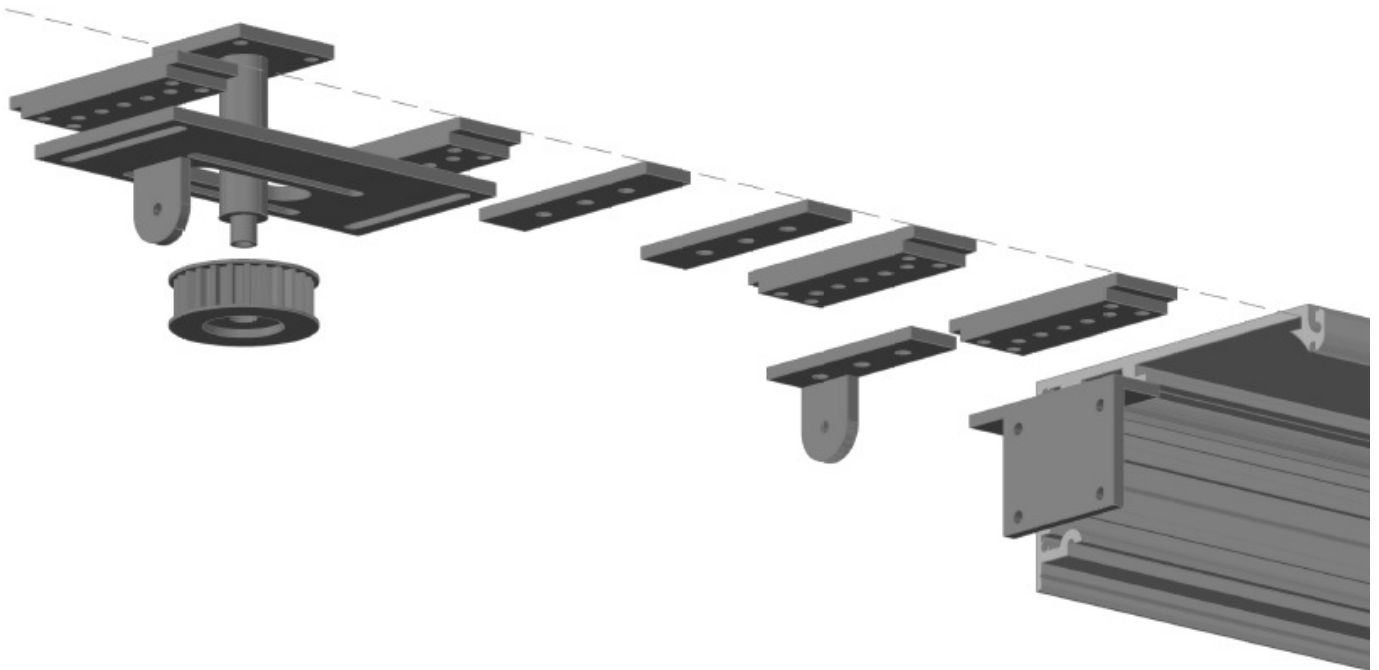

The Premier-Slide Compact uses a system of captive Plates that slide in the extrusion to secure the equipment into the operator. This makes installing the equipment very quick and easy.

Install new control unit to the right hand side of the motor within distance of motor wiring loom and connect motor to the left hand side socket connector.

The idler pulley assembly installs like the rest of the equipment into the right hand side of the operator.

#### **Idler Wheel Adjustment**

The belt tension should then be adjusted by loosening the 4 x Holding bolts around the shaft on the idler pulley assembly and then use the adjuster bolt, (turning clockwise to tighten) to adjust the belt tension.

Use the locking nut on the adjuster to secure in place and tighten the Holding bolts.

The belt should be adjusted fairly tight with no sagging of the belt or it may slip teeth causing the operator to lose its positions.

**Assembly of the Belt Brackets**

The belt bracket system comprises a long or short “L” bracket for connection to the door hanger. It also contains an aluminum belt housing, a rubber spacer and 2 x M6 bolts. (see Fig 17)

**Fig 17**

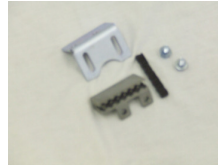

We recommend that the join of the belt should always be put in the housing that is connected to the short bracket.

Once the belt length has been selected and trimmed, the ends of the belt are pushed into the housing, with each end being inserted halfway ( i.e. 3 sections). (see Fig 18)

**Fig 18**



Once both ends are installed, the small rubber spacer block is pushed into the housing, which ensures the belt is pushed fully into its correct position. (see Fig 19 – Fig 21)

**Fig 19**



**Fig 20**



**Fig 21**



**Fig 23**

**Fig 22**

The belt housing can now be attached using the 2 x M6 bolts supplied. (See Fig 22 – Fig 23)



Once the housing has been attached, the bracket can be fixed to the door hanger bracket using the 2 x M6 hex bolts supplied. The height of the belt should be adjusted so that the belt runs straight before the final tightening of the bolts.



### **Program Switch Connection**

**Locate a suitable position for mode control switch and install using 2 x screws. If you plan to surface mount the switch, use adaptor plate supplied. If mounting to a hollow section such as aluminum frame mullion, the adaptor plate will not be required and the wiring can be concealed within the hollow chamber of the frame section.**

**Connect the wire loom into the right hand side of the control unit under the cover on the right (using the RJ45 plug) .**

**A standard IEC connector plug (kettle plug) is supplied and should be plugged into the Left Hand side of the control unit, then suitably routed to the fused spur and connected.**

**(Connection should only be made by suitably qualified personnel).**



## **Quick Setting Up Procedure**

**We recommend initial setting up of the door system without any sensors connected.**

**Before turning on mains power, check and set all dip switches for required operation.**

**Ensure the doors are in the mid open position, approx 70% apart.  
This will allow you to check which way the initial door movement is.**

**Switch the mains spur on and the doors will open slowly and will then close slowly.  
(if doors close, switch off and change motor direction dip switch on control unit,  
then switch back on again)**

**During this setup mode, the door opening size will be measured and stored. Initial  
setup is then complete.**

**The mode switch will be set initially to the closed position.**

**Press the test button on the control unit and the door will operate one full open /  
closed cycle.**

**Carry out any necessary adjustments to the door speeds and timer to suit door size /  
site Conditions by turning the adjusters with the correct size terminal screw driver.**

## Control Unit

The control unit is fully microprocessor controlled and has an integrated switched mode power supply (SMPS). It has two built in fuses rated at 3A 250V.

All the wiring is on the control unit under a small cover to the right. The unit uses our same push connectors and now has a common for each input and a zero volt for each of the powers.

The wiring is the same as the previous control unit (Safe, key etc..)

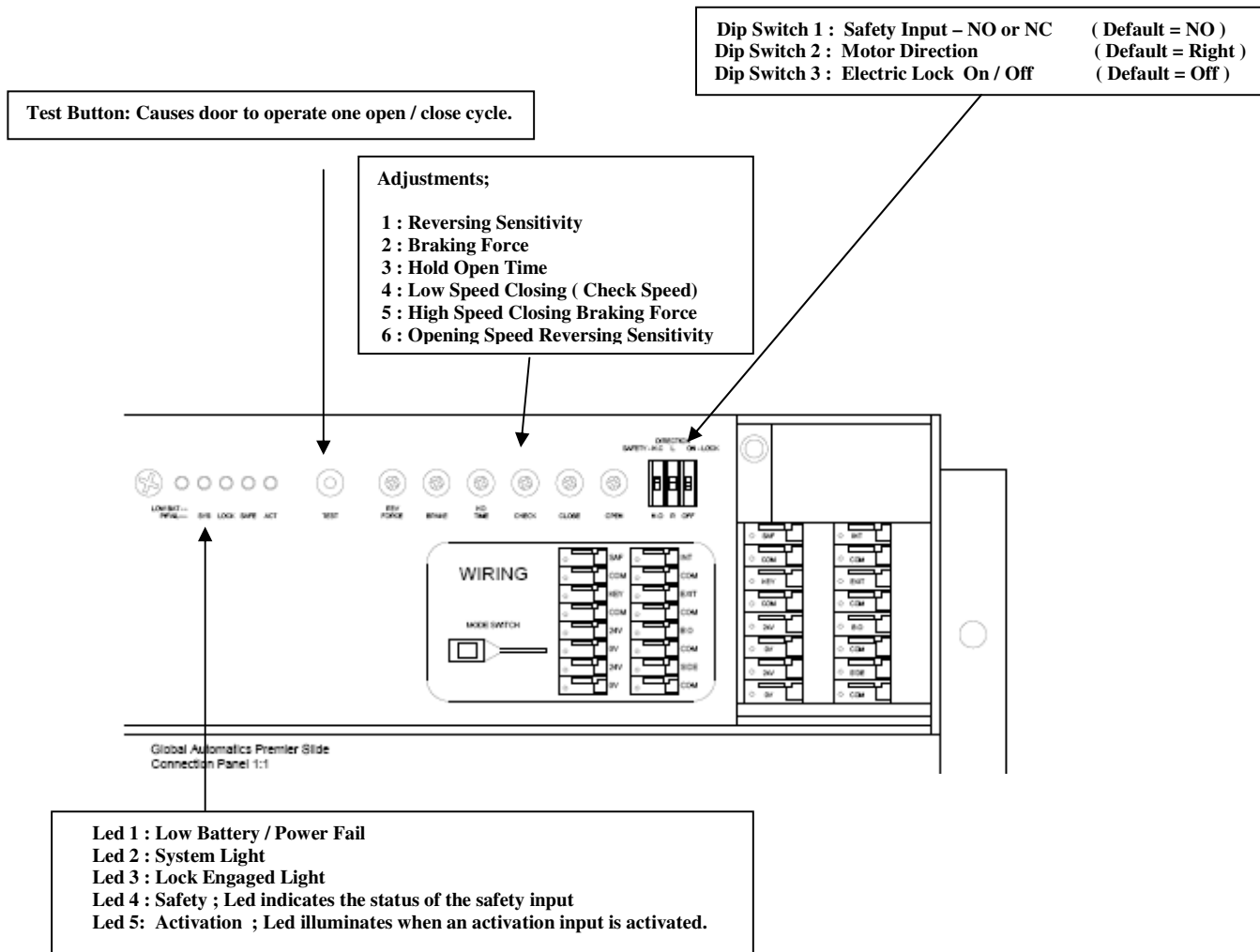

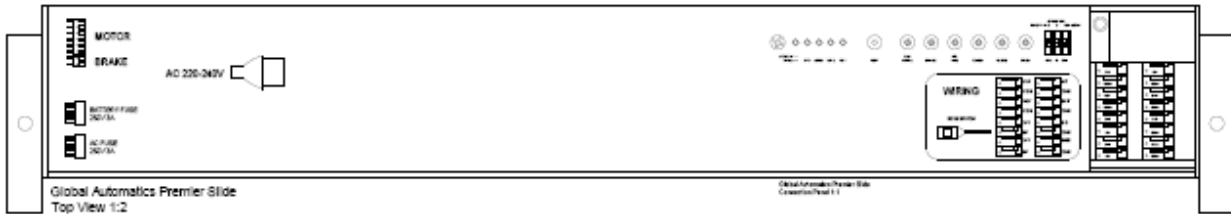

## **Battery Backup**

The battery unit is now integrated into the control unit. The battery is accessed by removing the two top screws nearest the cover on the right hand end plate of the control unit. Once the screws are removed you can slide out the endplate which has attached to it the battery tray.

The Battery LED Now has two functions:

- a) If the LED flickers quickly ( approx every second) this indicated a power failure
- b) If the LED flickers ( approx every over second) this indicates a low battery

## **Program switch**

The premier-slide is equipped with a press button control switch which allows the user to alternate between the different door functions.

Functions are selected by pressing the mode button once. The led will run from top to bottom between the functions with each press. Simply stop on the function you require (Indicated by Led). The door will reset its status and the correct function will be active.

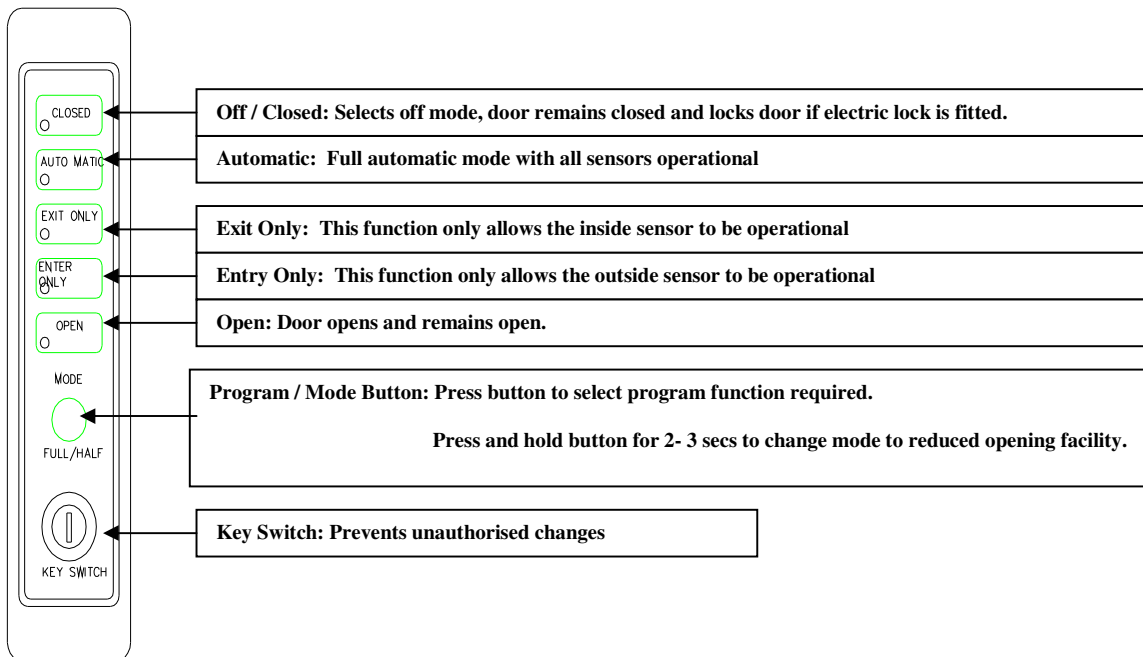

All options can be locked to prevent unauthorised changes by use of a key switch.

**Mode 1:** Summer: All functions are carried out with the door opening fully.

**Mode 2:** Winter: All functions are still available but the door opening is reduced to 70%.

The changing of the program modes to winter/summer is selected by holding the program button in until the Led on the switch changes from green to orange. At the same time the door will carry out a reset cycle and the door will open and close.

To reset to previous mode, simply hold the program button in again until Led's change back to Green.

**Please use the same procedure for a customer reset function.**

## Connection Board & Wiring ( Generic )

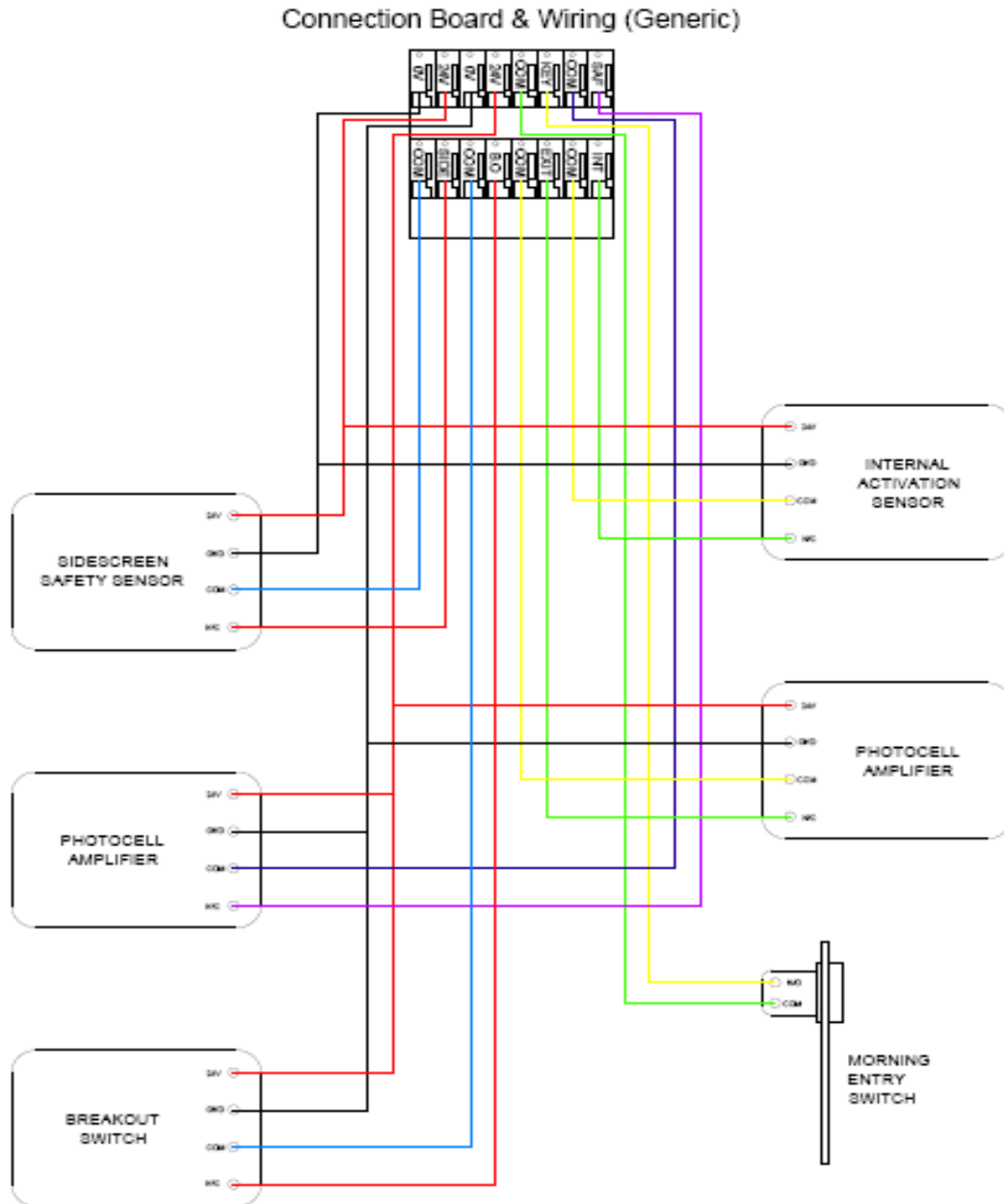

Note: Side screen safety sensor circuit is normally closed, it requires a link wire if not used.  
 The safety sensor circuit is switched N/O or N/C via control unit dip switch





## Connection Board & Wiring ( BEA Sensors )

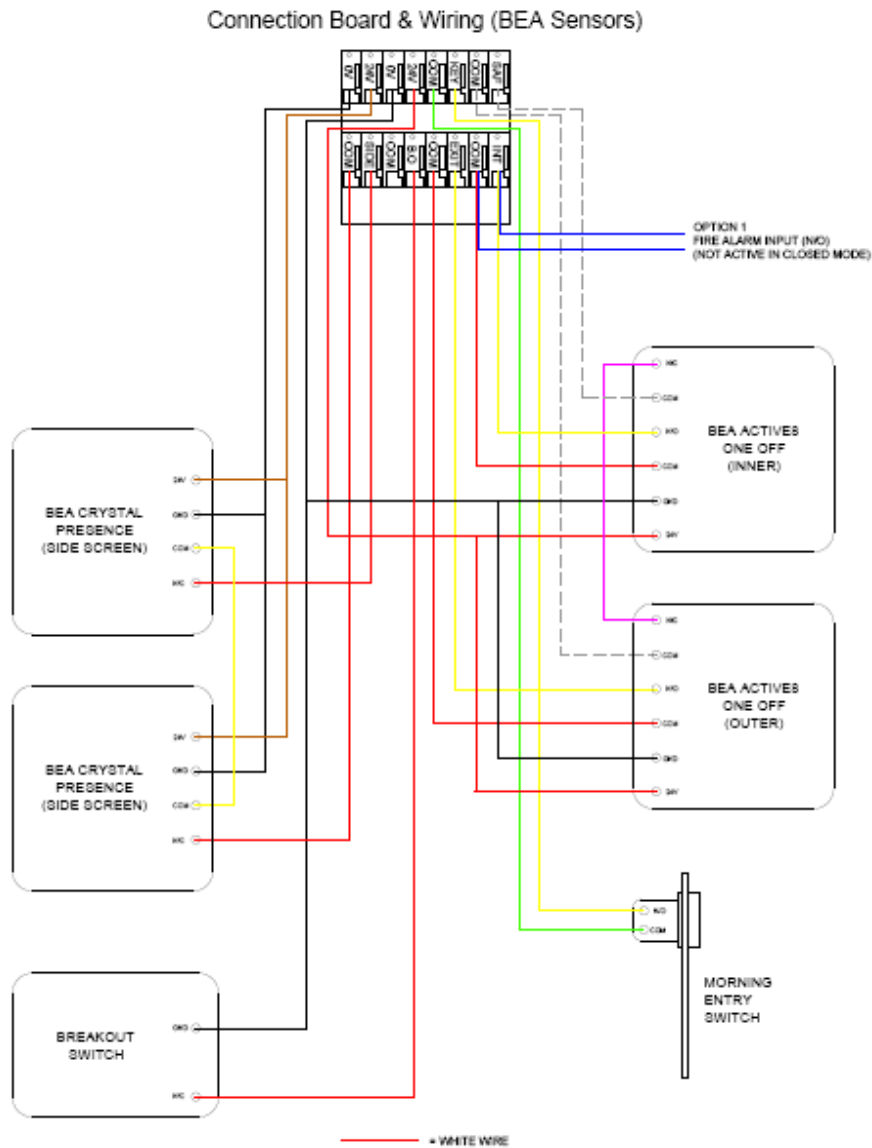



## **Fault Finding**

Depending upon the fault symptoms, we would always advise you to carry out a complete check of all mechanical parts and their adjustments to ensure the door is running smoothly.

Mechanical defect such as tight or jamming floor guides will cause friction problems as will debris trapped beneath a door.

Once the mechanical items have been checked, you can begin the electrical checks.

Before commencing detailed fault finding, it is good practice to reset the door control and observe the operation whilst resetting.

To reset the door, first switch off the operator mounted “on/off” switch and then the mains spur to off position.

Move the door leafs to the mid open position.

Wait 10 seconds and switch the mains spur on and followed by the “on/off” switch. The doors will open slowly ( if doors close, switch off and change motor direction Dip switch) and will then close slowly. The mode switch will be in the off position.

Select automatic mode and the door should work as normal, if not please refer to the Leds on the Control unit for fault indications

The control unit is equipped with a number of Led indicators which you can use for fault finding problems.

### **Led 1 : Low Battery / Power Fail**

This LED has two functions:

- 1) If the LED flickers quickly (approx every second) this indicated a power failure
- 2) If the LED flickers (approx every over second) this indicates a low battery

### **Led 2 : System Light**

This LED should flash constantly to indicate a healthy processor.

### **Led 3 : Lock Engaged Light**

This LED will illuminate if the Motor Lock Is engaged

### **Led 4 : Safety ; Led indicates the status of the safety input**

LED ON : Contact Closed  
LED OFF: Contact Open

### **Led 5 : Activation ; Led illuminates when an activation input is activated.**

This LED will illuminate if the door is being held open by an activation Input ( Radar, Press Pad, keypad etc)

## Trouble Shooting

<b><u>WHATS THE FAULT</u></b>	<b><u>POSSIBLE REASON</u></b>	<b><u>SOLUTIONS</u></b>
<b>THE DOOR KEEPS CLICKING</b>	POWER MAY HAVE BEEN CUT AFFECTING A RELAY	CHECK THE CONTROL UNIT FUSE
<b>THE DOOR IS STANDING OPEN</b>	THERE MAY BE A LOOSE CONNECTION  POWER MAY HAVE BEEN CUT AFFECTING A RELAY  THE SENSORS MAY BE WIRED INTO THE WRONG TYPE OF CIRCUIT  THE DOORS MAY BE BINDING  AN ACTIVATION DEVICE MIGHT BE CONSTANTLY ACTIVATING	CHECK ALL THE PLUG ARE CORRECTLY FITTED IN THE CONTROL UNIT.  CHECK THE CONTROL UNIT FUSE  CHECK NO / NC DIP SWITCH  CHECK THE DOORS SLIDE FREELY AND THERE IS NO FOR DEBRIE UNDER THE DOOR  CHECK FOR THE ACTIVATION LIGHT ON THE CONTROL UNIT <i>TURN OFF. DISCONNECT THE CONNECTION UNIT. SWITCH THE SAF SWITCH TO N/O AND REINSTATE THE MAINS.</i>  <i>IF THE DOOR RESETS AND CLOSE (EVEN SLOWLY) THE ACTIVATION IS FROM AN INPUT</i>  <i>IF THE DOOR REMAINS OPEN IT MAY BE A FAULTY COMPONENT.</i>
<b>THE DOOR ONLY OPENS ABOUT 2/3</b>	YOU MIGHT HAVE IT IN WINTER OPENING MODE  THE DOORS MAY BE BINDING	THE CHANGING OF THE MODE IS SELECTED BY HOLDING THE PROG BUTTON  IN UNTILL THE LED CHANGES COLOUR BETWEEN GREEN AND ORANGE  CHECK THE DOORS SLIDE FREELY AND THERE IS NO FOR DEBRIE UNDER THE DOOR
<b>THE DOOR WON'T WORK AT ALL</b>	THE POWER MAY BE OFF  THERE MAY BE A LOOSE CONNECTION  THE CHECK SPEED MAY NEED ADJUSTING  THE FUSE MAY HAVE BLOWN	CHECK THE MAINS HAS NOT BEEN INTERRUPTED AT THE SPUR  CHECK ALL THE PLUG ARE CORRECTLY FITTED IN THE CONTROL UNIT  CHECK THE CONNECTIONS OF ALL SENSORS ETC IN THE CONNECTION UNIT  CHECK THAT THE "CHECK" POT IS NOT SET UP TOO HIGH  CHECK THE DOOR IS IN THE CORRECT FUNCTION  CHECK THE DOORS SLIDE FREELY AND THERE IS NO FOR DEBRY UNDER THE DOOR  CHECK BOTH THE CONTROL UNIT AND CONNECTION UNIT FUSES
<b>THE MODE SWITCH HAS NO OPERATION</b>	THE MODE WIRE MAY BE SNAGGED  THERE MAY BE A LOOSE CONNECTION	LOOK FOR SNAGS/ BREAKS IN THE WIRE FROM MODE SWITCH TO CONTROL PANEL.  CHECK THE MODE SWITCH PLUG IS CORRECTLY IN THE CONTROL UNIT  CHECK THE PLUGS IN THE BACK ARE IN CORRECTLY- THE DOT AND THE LINE SHOULD LINE UP.
<b>DOOR RUNS IN CREEP SPEED ALL THE TIME</b>	THE SIDE SCREEN SENSORS MAY BE ACTIVATED	IS THERE ANY THING IN THE WAY THAT MAY BE ACTIVATING THE SAFETY SENSORS?  CHECK THE LINK BETWEEN THE SIDE SCREEN INPUTS IS IN PLACE AND NOT LOOSE



**Technical Specification**

	<u>Single Door</u>	<u>Double Door</u>
Max Door Width	2000mm	3000mm
Max Door Height	2500mm	2500mm
Max Door Weight	100kgs	160kgs
Mains Voltage	180v - 250 v ac	
Power Consumption Hour	Standby : Max 10W / Hour	Operating Mode : Max 150W /
Hold Open time	1 - 10 Sec	
Opening Speed	Max 600mm / Sec	
Closing Speed	Max 400mm / Sec	
Reduced Opening	70% of Opening Width (Fixed)	
Aux Power Supply	24v dc 2amp	
Ambient Temp	- 20 to +55	

**Warranty**

Global warrants to the authorised distributor that all products will be free from defects in materials and construction under normal use and for its intended purpose. Global obligation is limited to repairing or replacing components from its Factory within the 12month period from purchase. The warranty does not cover misuse, accidental damage or negligence.

There is no warranty or guarantee of fitness for a particular installation as each are bespoke to user and site conditions. Global does not authorise any distributor to offer any other warranty to any user on behalf of global.

Global shall not be liable in any event for special or subsequent damages from the buyer or third parties against the buyer. Unauthorised modifications to the operator exclude global from any warranty or resulting damage or liability.

Declaration of Conformity (CE )  
 73-25 EEC (Low voltage Directive)  
 89-336 EEC (Electromagnetic Compatibility )